



NetSC520 Demonstration Board Schematics

Elan™SC520 Microcontroller Demonstration Board With On-Board
Am79C973 10/100Mbps Ethernet and PC/104 and PC/104+ Expansion

27 SEPTEMBER 2000

NetSC520_Rev10.DSN

Schematic: 7200070-001
PC-Board: 1000070-001
Assembly: 0100070-001

© Copyright 2000 Advanced Micro Devices, Inc. All Rights Reserved.

Advanced Micro Devices, Inc. ("AMD") reserves the right to discontinue its products, or make changes in its products, at any time without notice.

The information in this publication is believed to be accurate at the time of publication, but AMD makes no representations or warranties with respect to the accuracy or completeness of the contents of this publication or the information contained herein, and reserves the right to make changes at any time, without notice. AMD disclaims responsibility for any consequences resulting from the use of the information included in this publication.

This publication neither states nor implies any representations or warranties of any kind, including but not limited to, any implied warranty of merchantability or fitness for a particular purpose. AMD's products are not designed, intended, authorized or warranted for use as components in systems intended for surgical implant into the body, or in other applications intended to support or sustain life, or in any other application in which the failure of AMD's product could create a situation where personal injury, death, or severe property or environmental damage may occur. AMD assumes no liability whatsoever for claims associated with the sale or use (including the use of engineering samples) of AMD products except as provided in AMD's Terms and Conditions of Sale for such product.

		
(C) Advanced Micro Devices, Inc. (800) 222-9323		
5204 E. Ben White Blvd. Austin, TX 78741 AMD Proprietary/All Rights Reserved		
Title	NetSC520 Demonstration Board	
Size	Document Number	Rev
C	COVER	1.0
Date:	Wednesday, January 10, 2001	Sheet 1 of 14

TABLE OF CONTENTS

Table of Contents

Page 01 -- Cover

Page 02 -- Table of Contents and Revision Information

Page 03 -- NetSC520 System Block Diagram

Page 04 -- Élan™SC520 Microcontroller

Page 05 -- SDRAM Main Memory Interface

Page 06 -- Non-volatile Memory

Page 07 -- IDE and ISA Control PAL; Interplane capacitors

Page 08 -- PC/104 ISA Expansion

Page 09 -- PC/104+ PCI Expansion

Page 10 -- PCnet™ FAST III Ethernet

Page 11 -- Serial Ports (RS-232)

Page 12 -- Crystals, Clocks, and CPU Bootstrap; Items to Include in B.O.M.

Page 13 -- CPU Power and Decoupling, CPU PLL Loop Filter, AMDebug and GPIO LEDs

Page 14 -- Reset, Main Power, and Backup Battery

Pre-release Revisions

Rev 0.3 -- Original Release For Review

Rev 0.4 -- Original Release For PC-Board CAD and Build Services
 Deleted RN1, R42, R43
 Flipped RN2-5 180degrees to facilitate PC-Board Routing

Rev 0.5 -- 2nd CAD Release
 Deleted Resistor SIPs [RP5-7,RP13] and changed to SMD R-Packs [RN13-19]
 Deleted R3; C25,49-51,65-68,76-78,113-115,24,52,53,69,70; and TC6,15,23,27; and 2mm Jumpers Z12,13
 Added AMD P/N and Siliconhills parttype to all schematic components
 Changed J8 to match existng AMD P/N
 Changed J4 to newer 1241-120G2 part number
 Changed power supply resistor values to standard 1% values:
 R61,63,67=4.99K, 1%;
 R62=5.36K, 1%;
 R66=1.82K, 1%;
 R60=165, 1%

Added Pre-Release Revision Information

Added Testpoints [TP10-13] to unused SC520 pins [Sheet 4]

Added PCICLK0 offsheet connection [Sheet 9]

Revised Block Diagram [Sheet 3]

Corrected some part number errors

Fixed a net name error on Sheet 13; corrected net is PONLED2_5

Swapped signals on R-PAKs and R-NETs to facilitate PC-Board routing

Added Interplane Capacitors Between VCC12-VCC5 and VCC3-VCC_CPU Split Power Planes

Post-release Revisions

Rev 1.0 -- 1st Board Respin

Added 1.5K pullup to CFG2 [sheet 4 and 12]

Fixed RESET switch pinout error [sheet 14]

Removed pullups from GPA[0..25] bus [sheet 8]

Made LEDs (vs GPIRQx) default population option and R58 a no-pop [sheet 13]

Fixed Ethernet SEEPROM wiring error [sheet 10]

Replaces xtal/osc dual footprint with an oscillator only footprint with added enable pin support [sheet 12]

Cleaned-up some text typos and changes IDE Header Part Number [sheets 7, 9, and 10]

NETSC520 SYSTEM BLOCK DIAGRAM

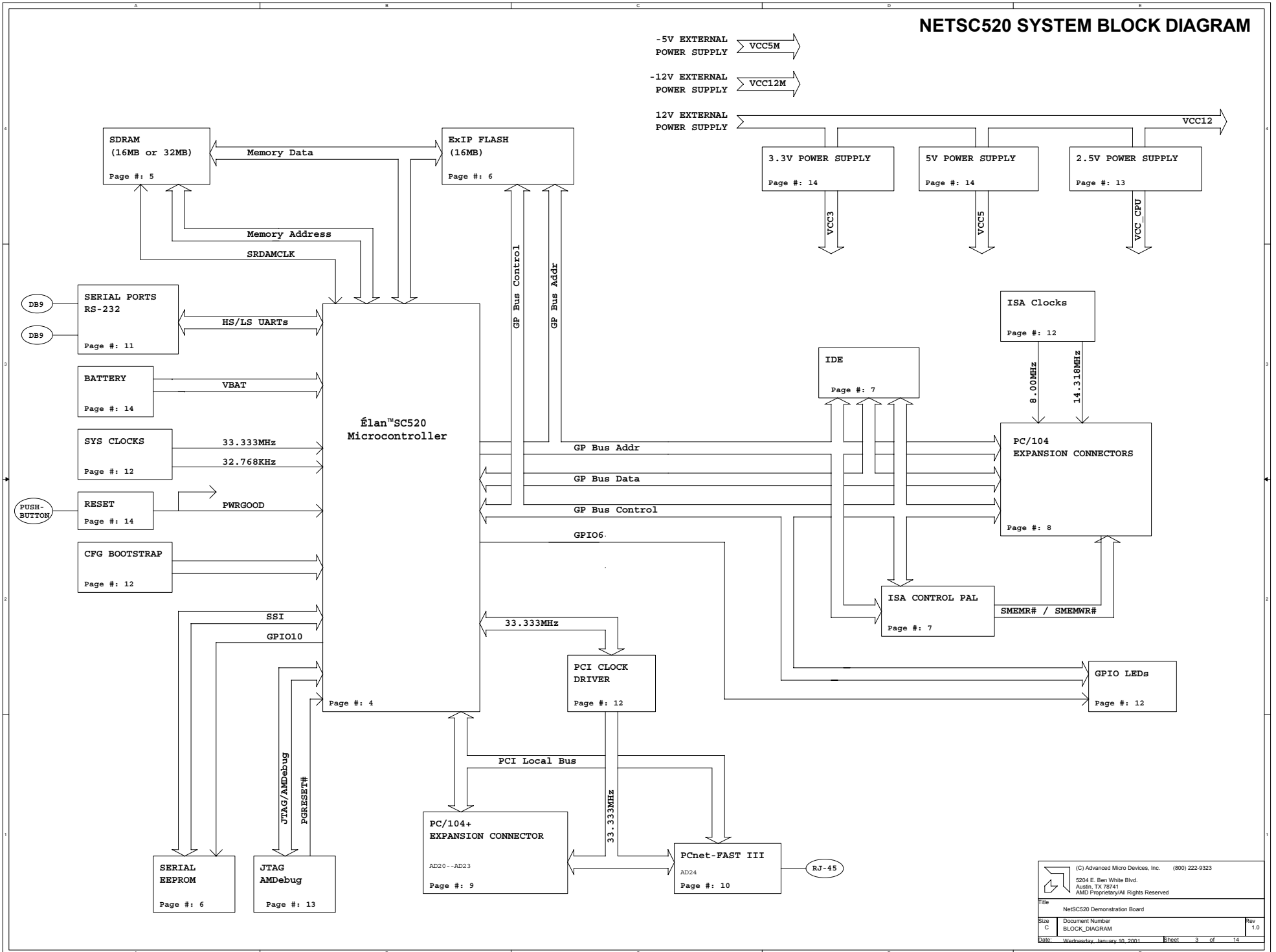

ElanSC520 MICROCONTROLLER

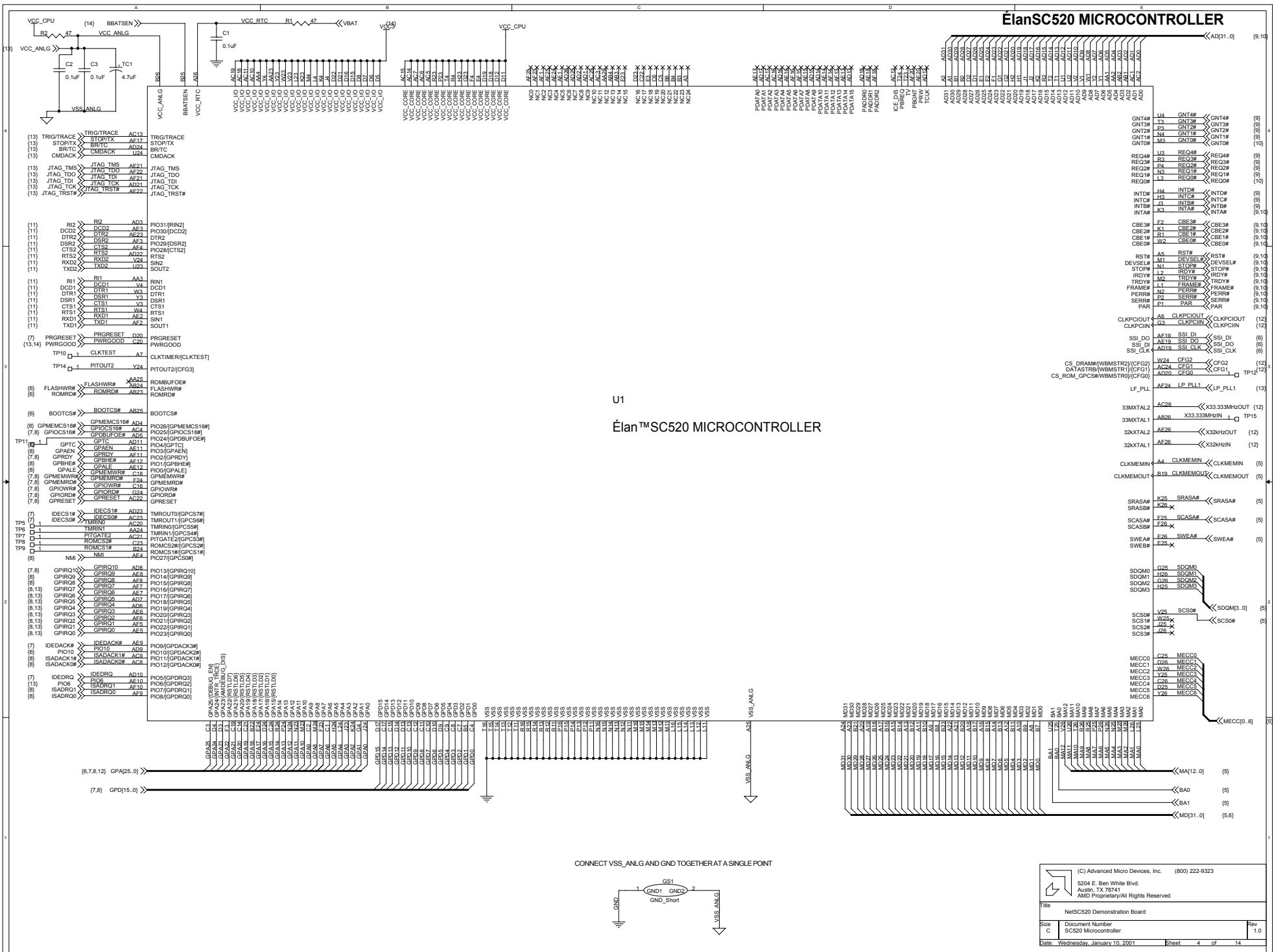

U1

Elan™SC520 MICROCONTROLLER

CONNECT VSS_ANLG AND GND TOGETHER AT A SINGLE POINT

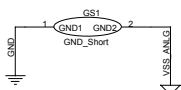

(C) Advanced Micro Devices, Inc. (800) 222-9323
 5204 E. Ben White Blvd.
 Austin, TX 78741
 AMD Proprietary/All Rights Reserved

Title: NetSC520 Demonstration Board

Size: Document Number: Rev 1.0
 C: SC520 Microcontroller

Date: Wednesday, January 10, 2001 Sheet 4 of 14

SDRAM MAIN MEMORY INTERFACE

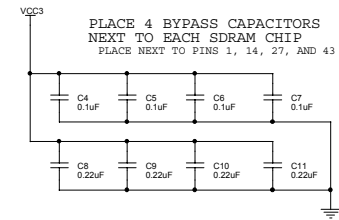
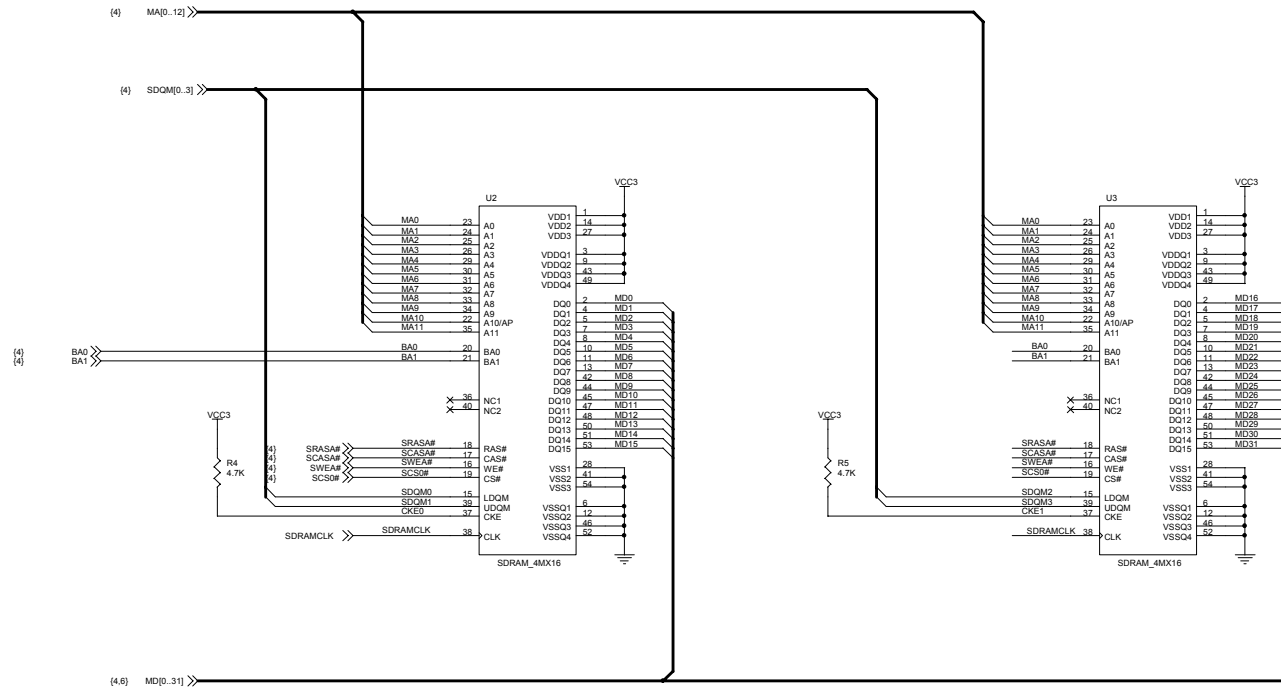

PULL-UP UNUSED ECC BITS

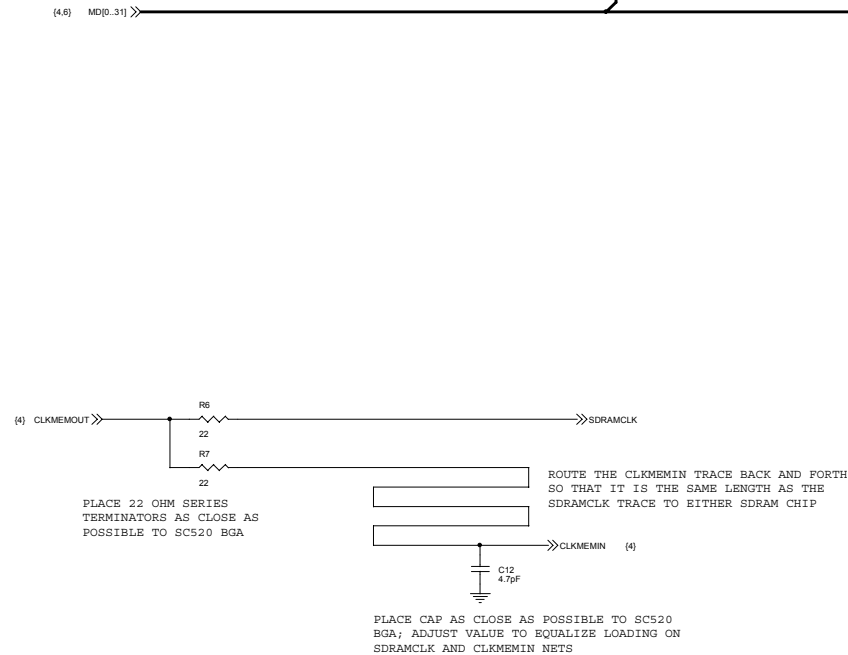
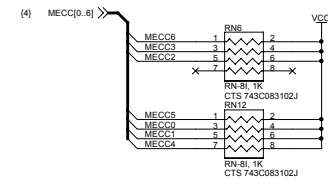

ROUTE THE SDRAMCLK "T" STYLE SO THAT THE TRACE LENGTH TO EACH SDRAM CHIP IS THE SAME

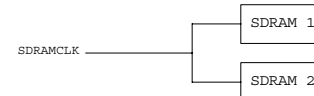

SDRAM POPULATION OPTIONS

16MBYTE SDRAM	4MX16: SAMSUNG K4S641632C
32MBYTE SDRAM	8MX16: SAMSUNG KS281632M

NON-VOLATILE MEMORY

ExIP Flash Memory (16 MByte)

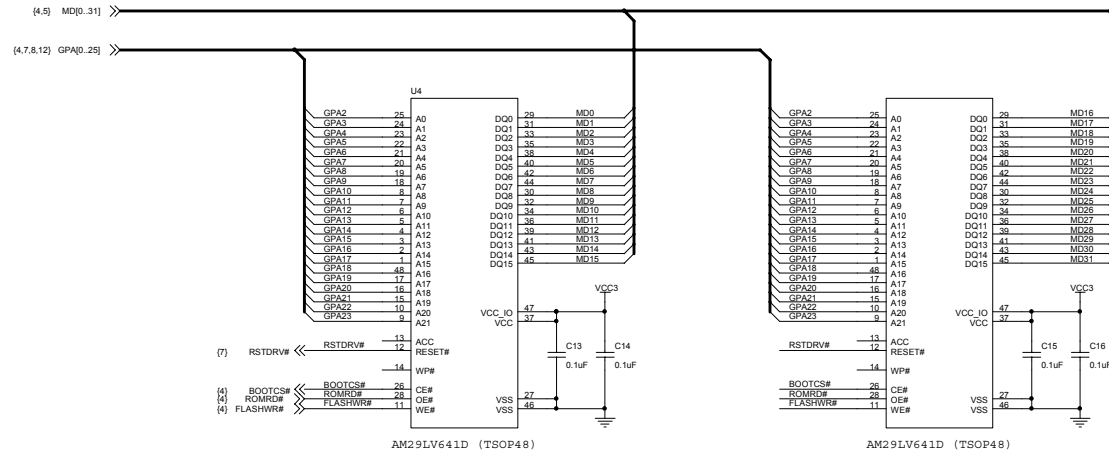

1Kbit Serial EEPROM (64x16) Synchronous Serial Interface--Microwire SEEPROM

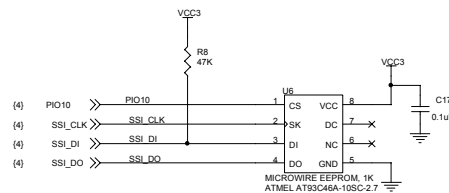

(C) Advanced Micro Devices, Inc. (800) 222-9323
5204 E. Ben White Blvd.
Austin, TX 78741
AMD Proprietary/All Rights Reserved

Title: NetSC520 Demonstration Board
Size: Document Number
C: Flash_MEM_CHIPS
Date: Wednesday, January 10, 2001 Sheet: 6 of 14 Rev: 1.0

IDE INTERFACE AND ISA CONTROL PAL

ISA CONTROL PAL

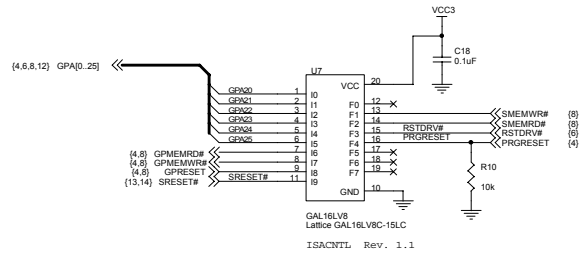

PAL EQUATIONS

$SMEMRD\# = \text{/GPA20} * \text{/GPA21} * \text{/GPA22} * \text{/GPA23} * \text{/GPA24} * \text{/GPA25} * \text{MEMRD\#}$;ASSERT SMSMRD# DURING AN ISA READ
 ;CYCLE TO ADDRESSES LESS THAN 1 MBYTE
 $SMEMWR\# = \text{/GPA20} * \text{/GPA21} * \text{/GPA22} * \text{/GPA23} * \text{/GPA24} * \text{/GPA25} * \text{MEMWR\#}$;ASSERT SMSMR# DURING AN ISA WRITE
 ;CYCLE TO ADDRESSES LESS THAN 1 MBYTE
 $RSTDRV\# = \text{/GPRESET}$;INVERT
 $PRGRESET = \text{/SRESET\#}$;INVERT

IDE INTERFACE (2.5" HARD DISK)

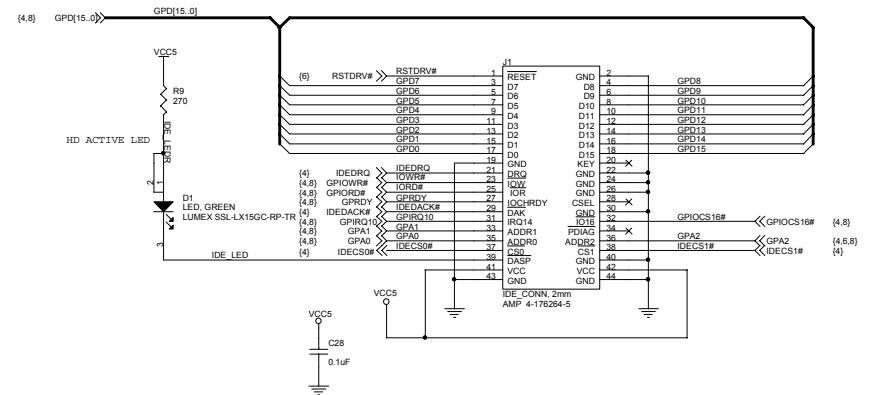

INTERPLANE CAPACITORS

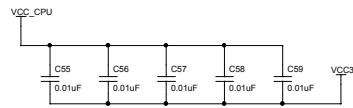

Place amongst signals where they cross between power planes.

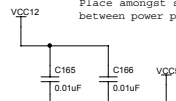

LUMEX LED (SOT23)



Top View

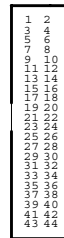

2mm IDE CONNECTOR
Top View

(C) Advanced Micro Devices, Inc. (800) 222-9323
5204 E. Ben White Blvd.
Austin, TX 78741
AMD Proprietary/All Rights Reserved

Title: NetSC520 Demonstration Board
Size: Document Number
C: PAL and IDE Interface
Rev: 1.0
Date: Wednesday, January 10, 2001 Sheet: 7 of 14

PC/104+ INTERFACE

PCI INTERFACE

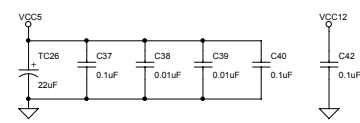
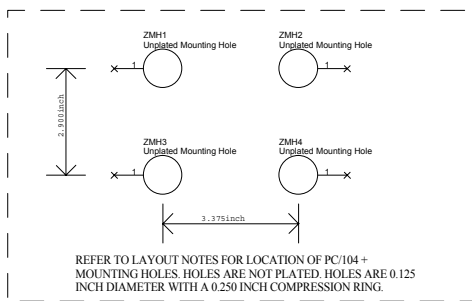
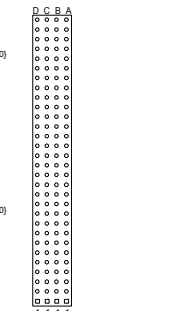
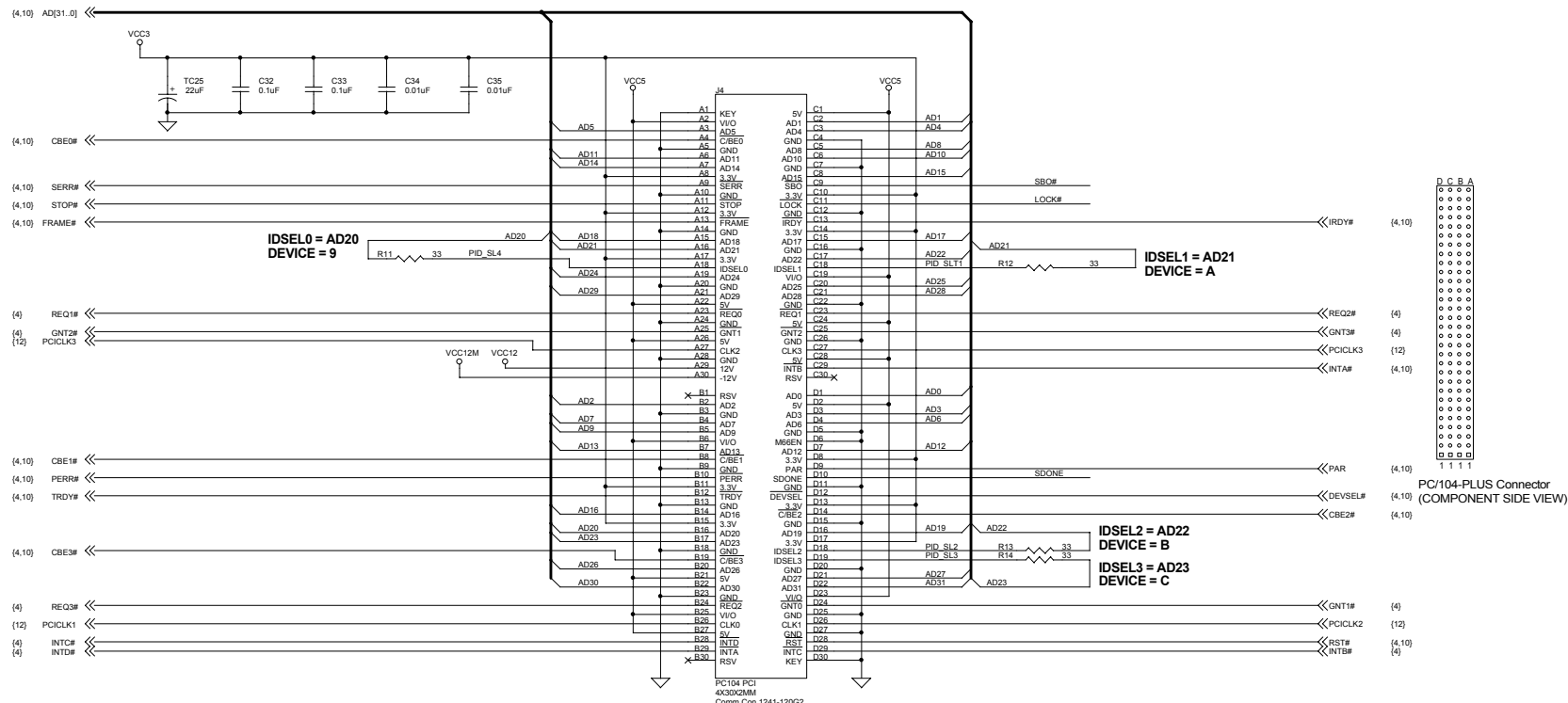

PCI Clock Terminators (Place Near Load)

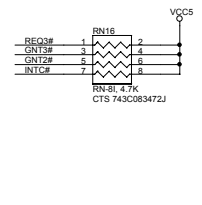
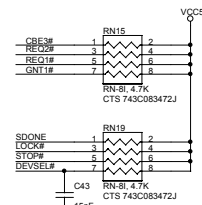
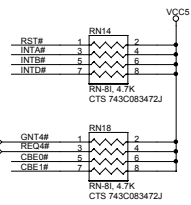
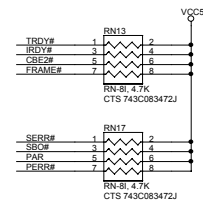
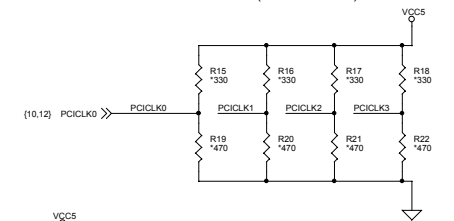

AM79C973 10/100 ETHERNET INTERFACE

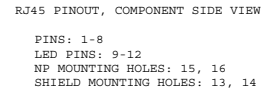
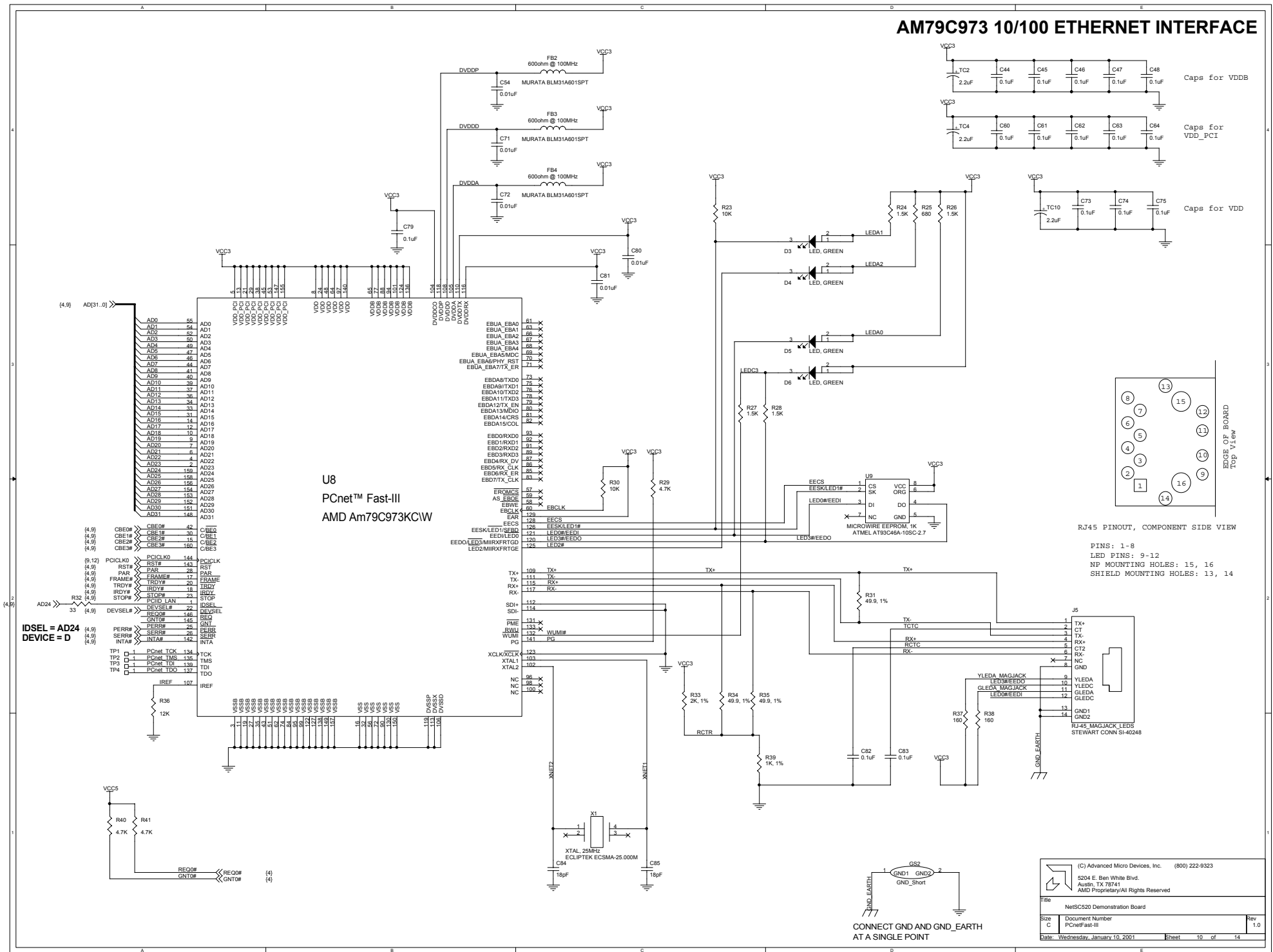

CONNECT GND AND GND_EARTH
AT A SINGLE POINT

SERIAL PORTS (RS-232)

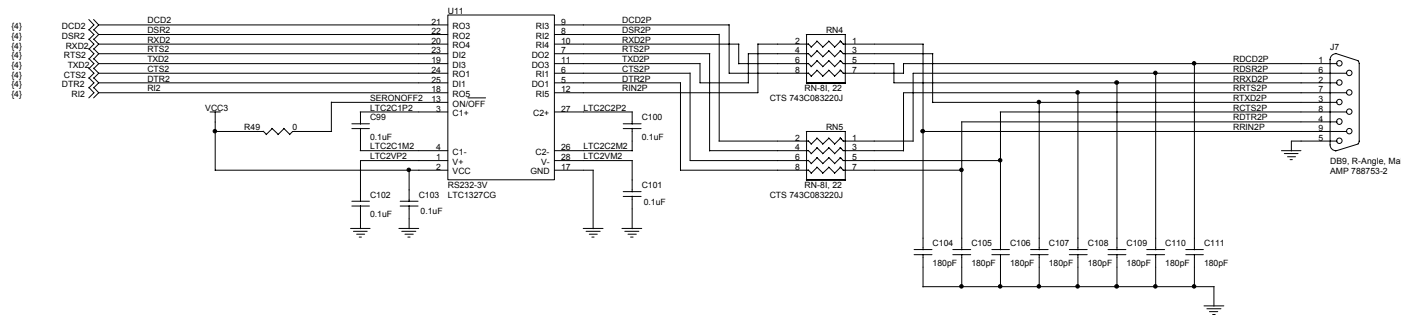
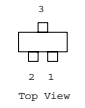
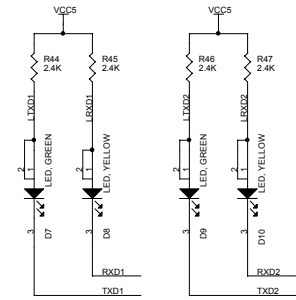
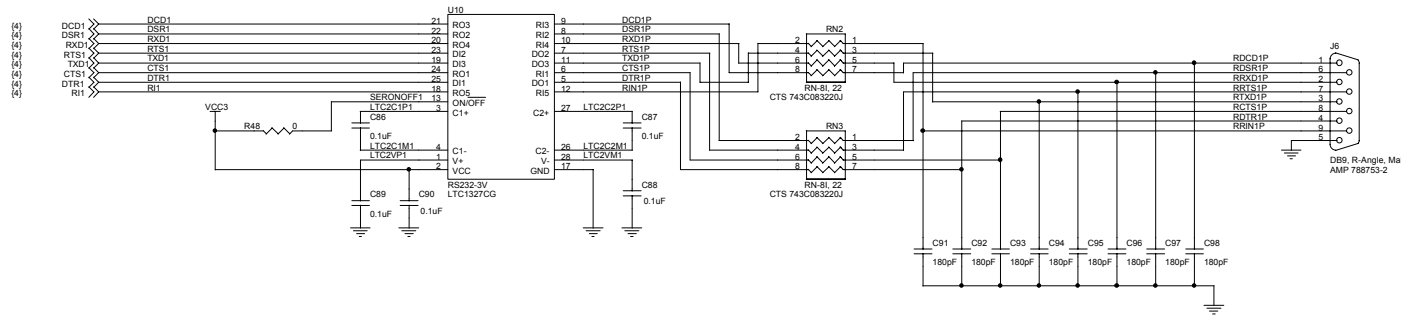

SYSTEM CLOCKS AND POWER-ON BOOTSTRAP

SC520 POWER-UP BOOTSTRAP

- BOOT FROM 181FT BOOTROM CONTROLLED FLASH ROM
- BOOT ROM ON MD[0..31] BUS
- USER CAN SET AMDebug CONFIGURATION

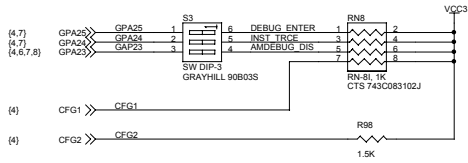

SC520 POWER-ON RESET LATCHED DATA

- USER CAN SELECT CODE LATCHED AT RESET

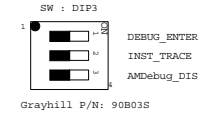
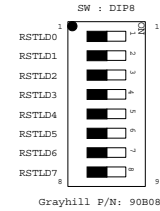
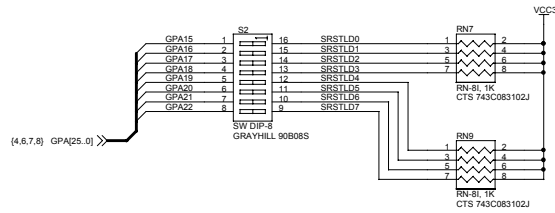

COMPONENTS TO INCLUDE IN B.O.M. FOR ASSEMBLED BOARDS

Z1 BOM Include PC104 Standoff Comm Con HW-PC600P	Z7 BOM Include PC104 Standoff Nut Comm Con HW-PC440NP	Z4 BOM Include 2mm Jumper Samtec 2SN-BK	Z17 BOM Include Power Supply Eipac W4012-750
Z6 BOM Include PC104 Standoff Comm Con HW-PC600P	Z11 BOM Include PC104 Standoff Nut Comm Con HW-PC440NP	Z9 BOM Include 2mm Jumper Samtec 2SN-BK	
Z10 BOM Include PC104 Standoff Comm Con HW-PC600P	Z15 BOM Include PC104 Standoff Nut Comm Con HW-PC440NP	Z5 BOM Include PLCC20 SOCKET, W/ POSTS SAMTEC PLCC-020-TA	
Z14 BOM Include PC104 Standoff Comm Con HW-PC600P	Z3 BOM Include 2mm Jumper Samtec 2SN-BK	Z16 BOM Include 12mm 3V Lithium Battery Panasonic BR1225	
Z2 BOM Include PC104 Standoff Nut Comm Con HW-PC440NP	Z8 BOM Include 2mm Jumper Samtec 2SN-BK		

SC520 32KHz and 33MHz CRYSTALS

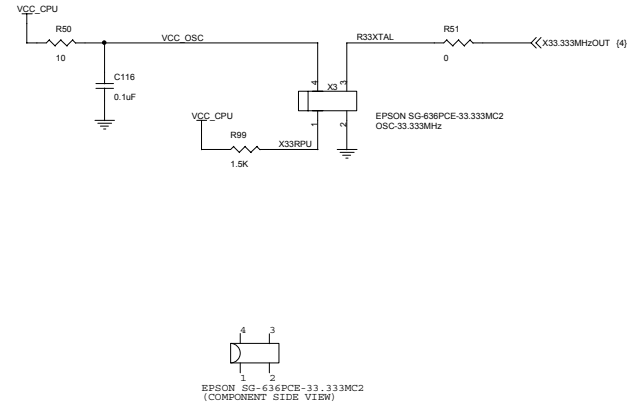
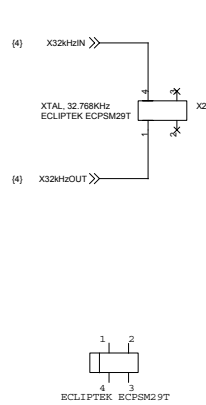

PCI Clock Driver

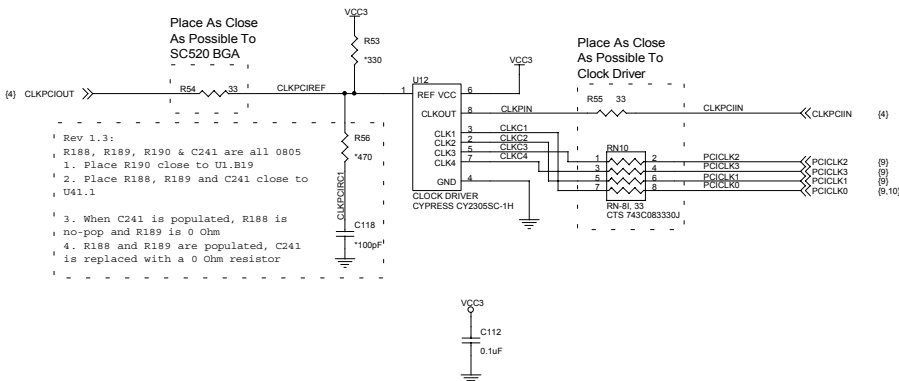

ISA Clocks

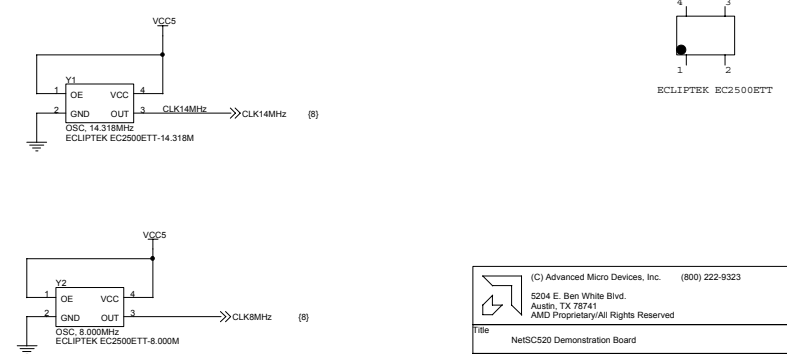

(C) Advanced Micro Devices, Inc. (800) 222-9323
5204 E. Ben White Blvd.
Austin, TX 78741
AMD Proprietary/All Rights Reserved

CPU POWER, AMDebug, CPU DECOUPLING, RTC PLL LOOP FILTER, AND GPIO LED

JTAG & AMDebug Port

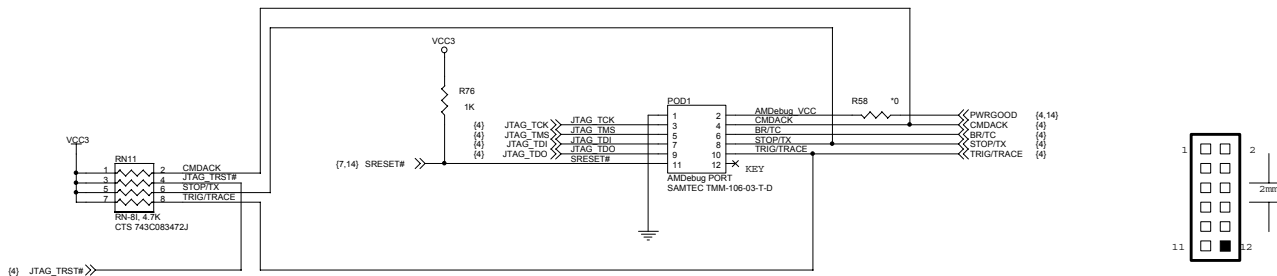

VCC_CPU Decoupling

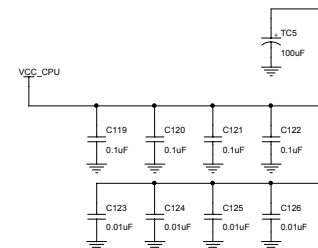

GPIO CONTROLLED LEDs

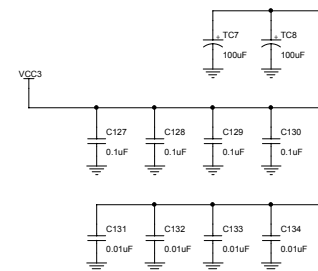
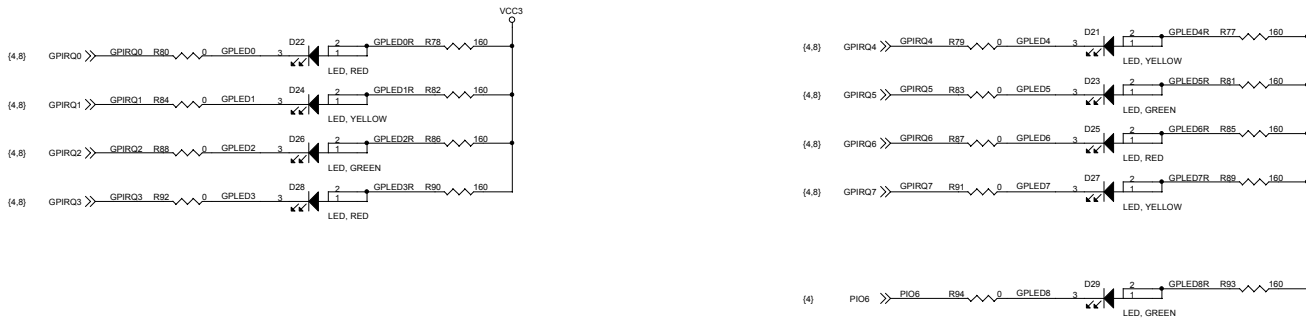

Place the above Caps under the BGA (Back side of the board)

2.5V Regulator

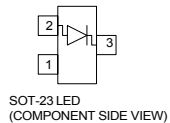
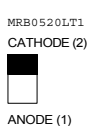
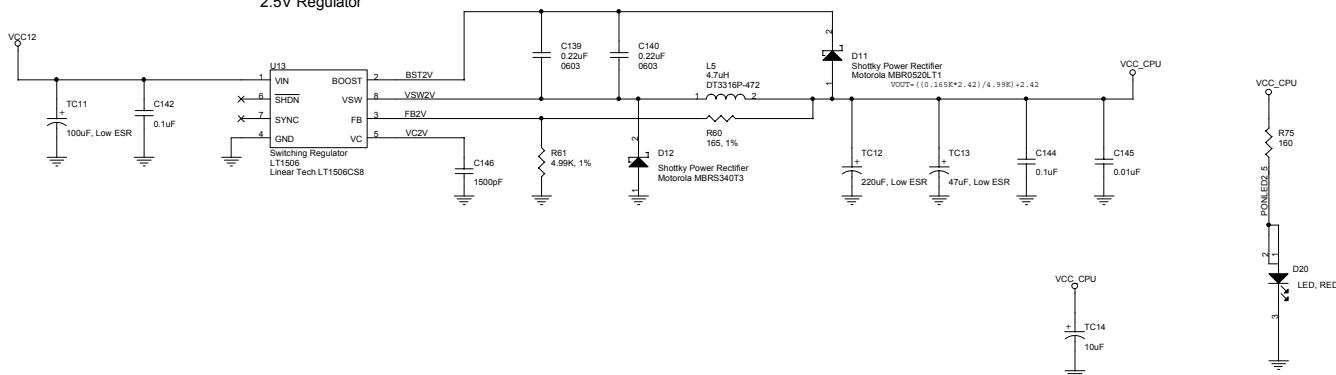

PLL Loop Filter

(PLACE CLOSE TO BUS20 BGA)

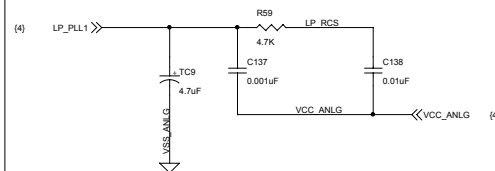

RESET, MAIN POWER, AND BACKUP BATTERY

Power Connector
Use 12V Power Cube
Mfg X/ Part Number X

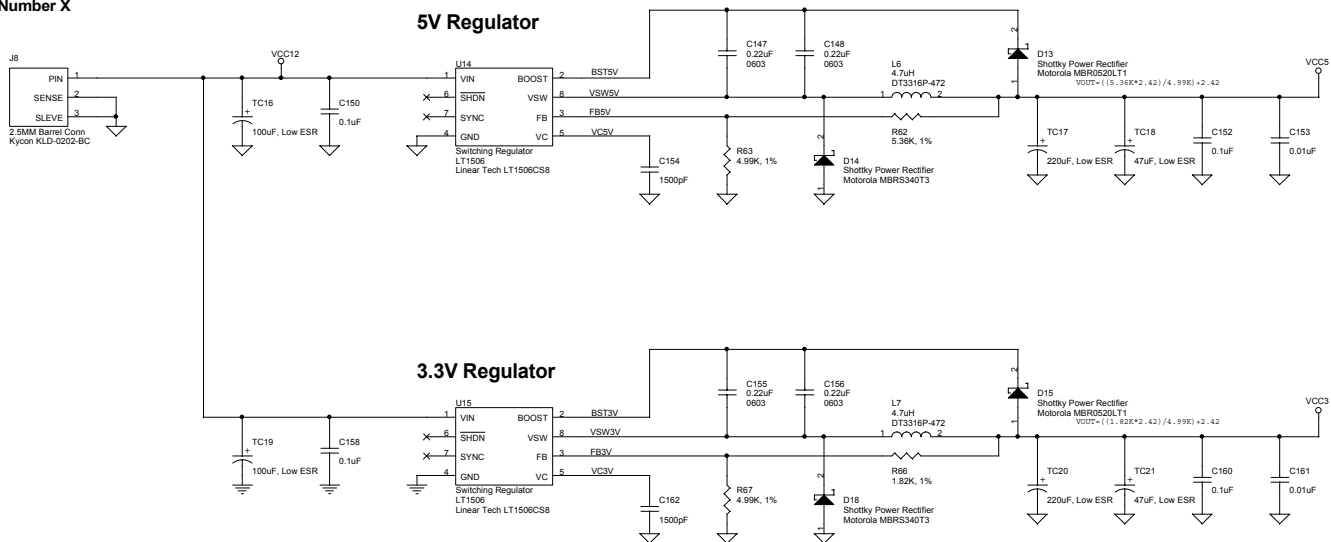
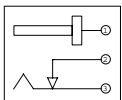

Power LEDs

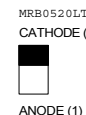
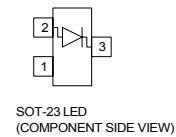
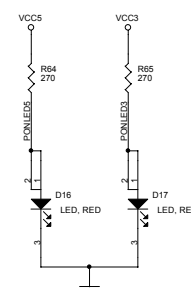

System Reset Control

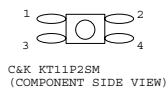
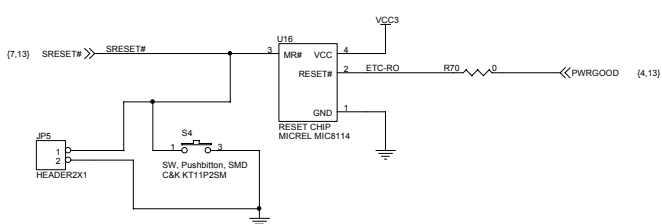

RTC VBAT Power

(PLACE CLOSE TO SC520 BGA)

