



Am79C930

PCnet™-Mobile Single Chip Wireless LAN Media Access Controller

DISTINCTIVE CHARACTERISTICS

- Capable of supporting the IEEE 802.11 standard (draft)
- Supports the Xircom Netwave™ Media Access Control (MAC) protocols
- Supports MAC layer functions
- Individual 8-byte transmit and 15-byte receive FIFOs
- Integrated intelligent 80188 processor for MAC layer functions
- Glueless PCMCIA Bus interface conforming to PC Card Standard - Feb. 1995
- Full PCMCIA software interface support for PC Card Standard - Feb. 1995
- Glueless ISA (IEEE P996) Bus interface with full support for Plug and Play release 1.0a
- Glueless SRAM interface for MAC operations, supporting up to 128 Kbytes of memory
- Glueless Flash memory interface, supporting up to 128 Kbytes of non-volatile memory for MAC control code, PCMCIA configuration parameters, and ISA Plug and Play configuration parameters
- Provides integrated Transceiver Attachment Interface (TAI), supporting Frequency-Hopping Spread Spectrum, Direct Sequence Spread Spectrum, and Infrared physical-layer interfaces
- Antenna diversity selection support
- Fabricated with submicron CMOS technology with low operating current
- Supports dual 3 V and 5 V supply applications
- Low-power mode allows reduced power consumption for critical battery-powered applications
- 144-pin Thin Quad Flat Pack (TQFP) package available for space critical applications, such as PCMCIA
- JTAG Boundary Scan (IEEE 1149.1) test access port for board-level production test

GENERAL DESCRIPTION

PCnet-Mobile (Am79C930) is the first in a series of mobile networking products in AMD's PCnet Family. The Am79C930 device is the first single-chip wireless LAN Media Access Controller (MAC) supporting the IEEE 802.11 (draft) standard and the Xircom Netwave™ MAC protocols. The Am79C930 device is designed to have a flexible protocol engine to allow for industry standard and proprietary protocols. Protocol firmware for Xircom Netwave and IEEE 802.11 (draft) MAC protocols are supplied by AMD. It is pin compatible with the PCMCIA bus or the ISA (Plug and Play) bus through a pin strapping option.

The Am79C930 device contains a PCMCIA/ISA Bus Interface Unit (BIU), a MAC control unit, and

a Transceiver Attachment Interface (TAI). The TAI supports Frequency Hopping Spread Spectrum, Direct Sequence Spread Spectrum, and infrared physical layer interfaces. In addition, a power down function has been incorporated to provide low standby current for power-sensitive applications.

The Am79C930 device provides users with a Media Access Controller that has flexibility (i.e., bus interface, protocol, and physical layer support) to allow the design of multiple products using a single device. By having all the necessary MAC functions on a single chip, users only need to add memory and the physical layer in order to deliver a fully functional wireless LAN connection.

ORDERING INFORMATION

Standard Products

AMD standard products are available in several packages and operating ranges. The order number (Valid Combination) is formed by a combination of:

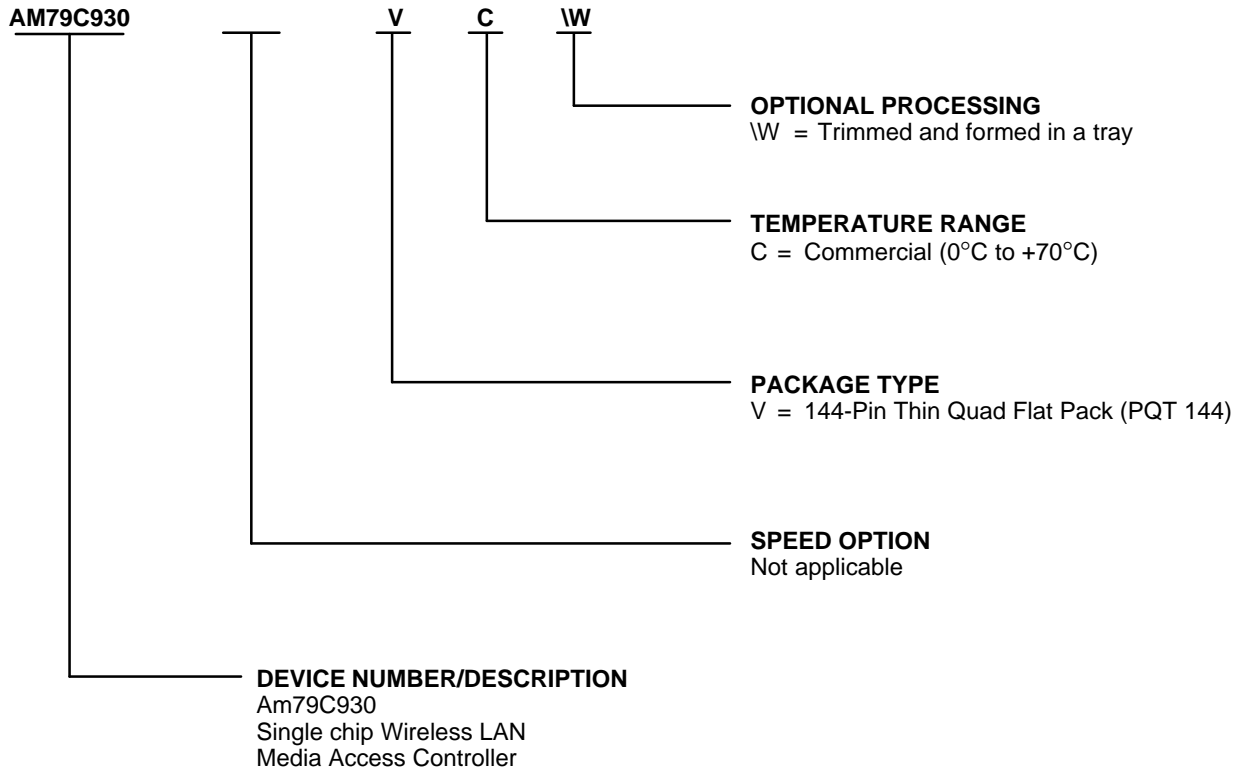

Valid Combinations	
Am79C930	VC\W

Valid Combinations

Valid Combinations list configurations planned to be supported in volume for this device. Consult the local AMD sales office to confirm availability of specific valid combinations and to check on newly released combinations.

BLOCK DIAGRAM

PCMCIA Mode

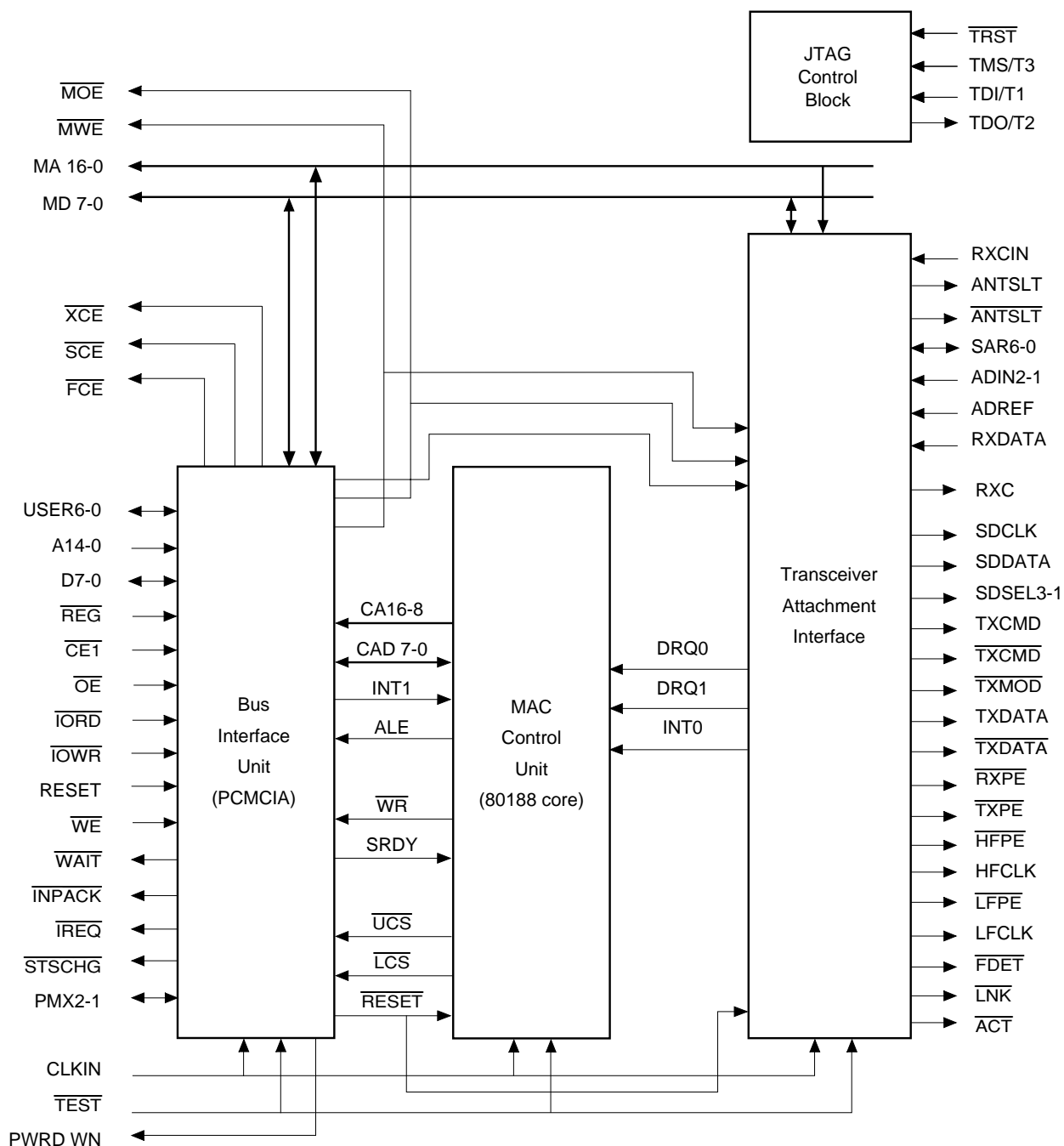

20183A-2

BLOCK DIAGRAM
Bus Interface Unit

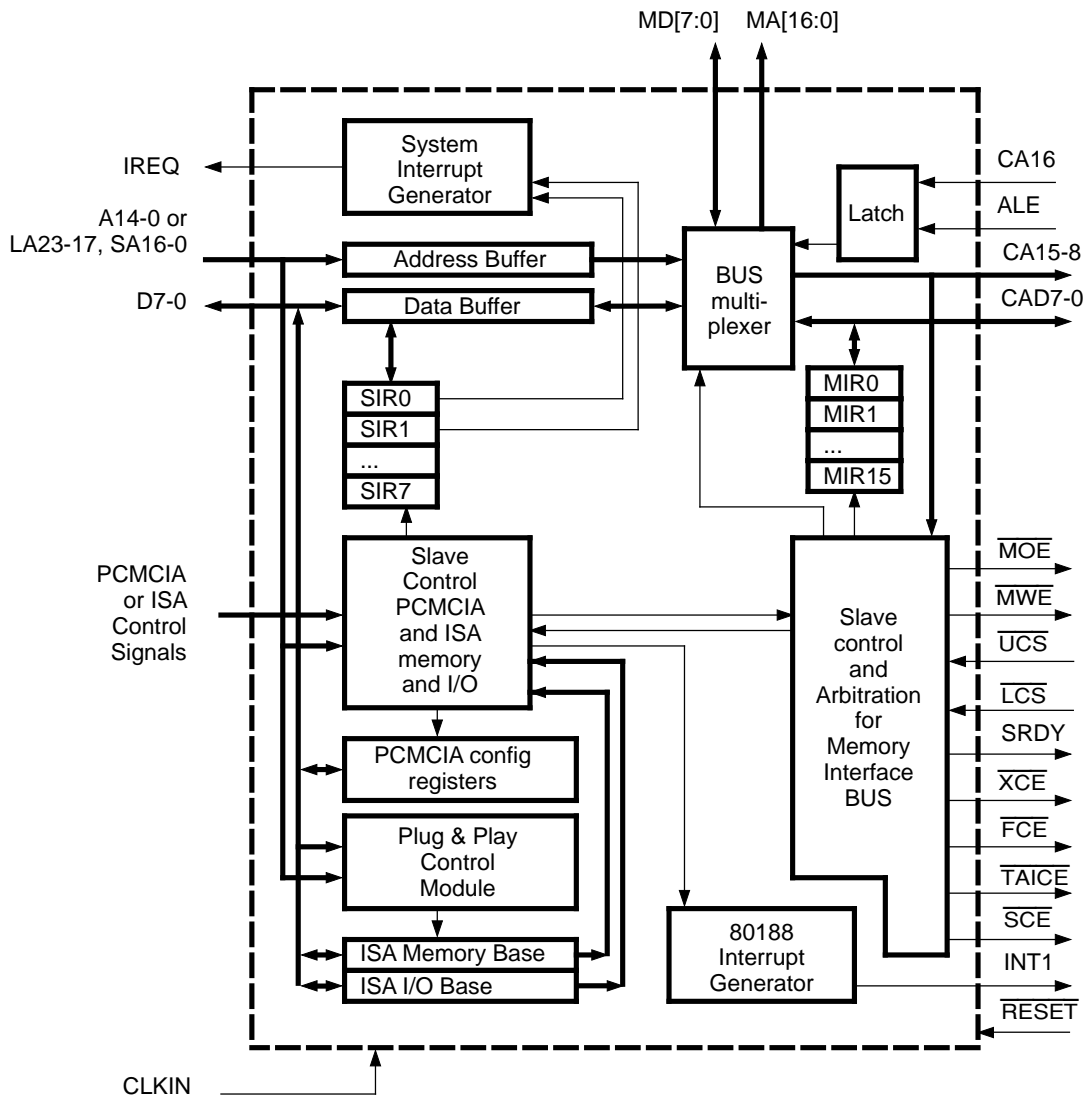

20183A-3

BLOCK DIAGRAM

Transceiver Attachment Interface Unit

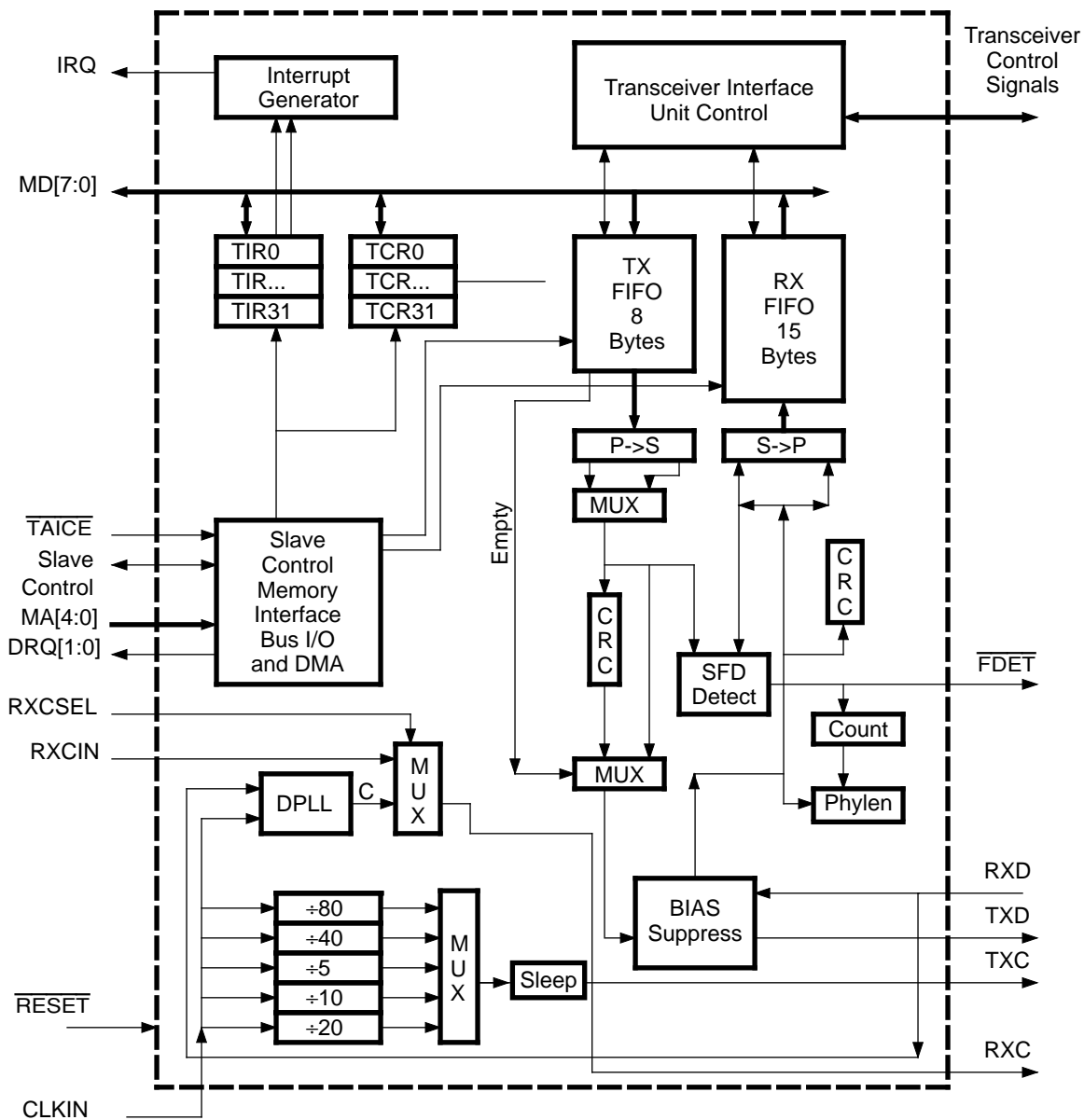

20183A-4