

# Next-Generation AMD Opteron™ Processor with Direct Connect Architecture

## 2P Server and Workstation Comparison

### AMD OPTERON™ PROCESSOR-BASED 2P SERVER AND WORKSTATION

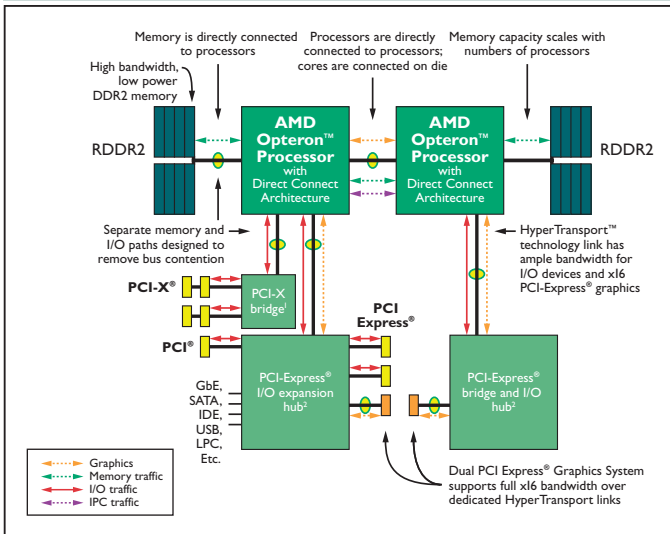

#### DIRECT CONNECT ARCHITECTURE

### AMD OPTERON™ PROCESSOR-BASED SYSTEM

#### AMD64

- » Enables simultaneous high-performance 32- and 64-bit computing
- » Delivers industry-leading performance-per-watt capabilities
- » AMD PowerNow!™ technology with Optimized Power Management provides power-on-demand computing and can help lower TCO
- » AMD's native dual-core implementation enables one platform to meet the needs of multi-tasking and multi-threaded environments, providing platform longevity
- » Hardware-assisted AMD Virtualization™ and Direct Connect Architecture provide a balanced approach to help improve virtualization performance, enabling more virtual machines to run per server

#### INTEGRATED RDDR2 MEMORY CONTROLLER

- » Low latency for fast memory reads
- » Memory bandwidth scales as processors are added
- » AMD Opteron™ processors with energy efficient RDDR2 memory offer greater memory bandwidth, improved memory RAS and cost savings

#### HYPERTRANSPORT™ TECHNOLOGY

- » At up to 8GB/s bandwidth per link, HyperTransport technology provides sufficient bandwidth for supporting existing interconnects including Fibre Channel, Gigabit Ethernet, PCI-X®, PCI-X® 2.0, PCI Express®, Serial-ATA, Serial Attached SCSI and 10G Ethernet

### INTEL XEON PROCESSOR-BASED 2P SERVER AND WORKSTATION

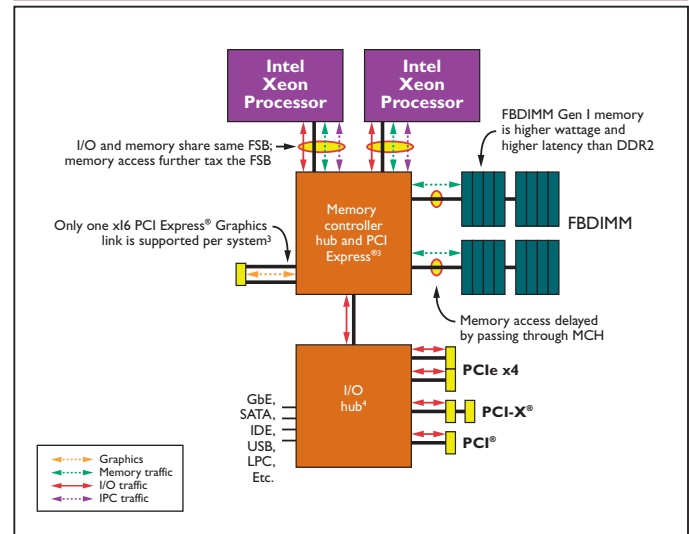

#### FRONT SIDE BUS-BASED ARCHITECTURE

### INTEL XEON PROCESSOR-BASED SYSTEM

#### EM64T

- » Allows 32- and 64-bit simultaneous computing
- » Intel SpeedStep technology and demand-based switching
- » Hardware-assisted VT must run memory-intensive virtualization applications over a shared front side bus

#### "NORTHBRIDGE"-STYLE MEMORY CONTROLLER VIA FRONT SIDE BUS

- » Passage through memory controller hub delays memory reads
- » Memory and I/O must share FSB bandwidth, further reducing the efficiency of the FSB

#### MEMORY CONTROL HUB (MCH)-BASED I/O HUB

- » With one MCH per system, PCI Express® interface integration onto MCH limits expansion options
- » Workstation systems limited to a single PCIe x16 link with the Intel 5000X chipset

<sup>1</sup> AMD-8132™ HyperTransport PCI-X® Tunnel  
<sup>2</sup> Third-Party Chipsets  
<sup>3</sup> Intel 5000P, 5000V and 5000X Chipset  
<sup>4</sup> Intel 6300ESB I/O Controller





SYSTEM COMPARISON	AMD OPTERON™ 2000 SERIES	INTEL XEON 5000 <sup>1</sup> SERIES	INTEL XEON 5100 <sup>1</sup> SERIES
Modular, glueless scalability	Yes	Requires Northbridge	Requires Northbridge
SMP capabilities	Up to 2 Sockets/4 Cores	Up to 2 Sockets/4 Cores	Up to 2 Sockets/4 Cores
Direct Connect Architecture	Yes	No	No
Dual-Core technology	Yes	Yes	Yes
High-Performance 32-bit and 64-bit computing	AMD64	EM64T	EM64T
HyperTransport™ technology	Yes	No	No
Integrated DDR2 memory controller	Yes	No	No
Hardware-assisted virtualization	AMD-V™	VT	VT
Front side bus frequency	1800 – 3000MHz <sup>2</sup>	1066MHz	1333MHz
Front side bus bandwidth	14.4 – 24GB/s <sup>1</sup>	17GB/s	21.3GB/s
Maximum Inter-processor bandwidth	8.0GB/s	8.5GB/s	10.6GB/s
Memory support	DDR2 400/533/667	FBDIMM 533/667	FBDIMM 533/667
Memory bandwidth 2P system	21.2GB/s <sup>1†</sup>	21.2GB/s	21.2GB/s
Maximum graphics support	Dual PCI <sup>®</sup> e x16	PCIe <sup>®</sup> x16*	PCIe <sup>®</sup> x16*
L1 cache size (max.)	64KB (Data) + 64KB (Instruction) per core	16KB (Data cache per core)+ 12K μ OPS(Trace cache per core)	32KB (Data)+ 32KB (Instruction) per core
L2 cache size (max.)	1MB per core	2MB per core	4MB (shared)
Maximum I/O bandwidth 2P system	32.0GB/s <sup>1†</sup>	14GB/s	14GB/s
SIMD instruction set support	SSE, SSE2, SSE3	SSE, SSE2, SSE3	SSE, SSE2, SSE3

**DEDICATED BANDWIDTH**

**SHARED BANDWIDTH**

<sup>\*</sup> 5000X Chipset  
<sup>1</sup> The AMD Opteron™ processor does not have a front side bus. The processor to memory controller interface is on the processor die  
<sup>1†</sup> AMD 2P System – AMD Opteron 2000 Series with 1 HyperTransport™ Inter-processor Bus and 4 HyperTransport I/O Buses with DDR2 667 memory  
<sup>1</sup> With Intel E5000P/E5000V chipset  
(<http://developer.intel.com/products/chipsets/e7505/index.htm> and <http://developer.intel.com/products/chipsets/e7525/index.htm>)

AMD (NYSE:AMD) designs and produces innovative microprocessors and low-power processor solutions for the computer, communications, and consumer electronics industries. AMD is dedicated to delivering standards-based, customer-focused solutions for technology users, ranging from enterprises and governments to individual consumers. For more information visit [www.amd.com](http://www.amd.com).

<b>TECHNICAL SUPPORT</b>	<b>USA &amp; CANADA:</b> 800-222-9323 OR 408-749-5703	<b>FRANCE:</b> 0800-908-621
	<b>USA &amp; CANADA PC MICROPROCESSOR:</b> 408-749-3060	<b>GERMANY:</b> +49-89-450-53199
	<b>USA &amp; CANADA EMAIL:</b> HW.SUPPORT@AMD.COM	<b>ITALY:</b> 800-877224
	<b>LATIN AMERICA EMAIL:</b> AMDXSRPO@VSR.AMD.BR	<b>EUROPE EMAIL:</b> EURO.TECH@AMD.COM
	<b>EUROPE &amp; UK:</b> +44-0-1276-803299	<b>FAR EAST FAX:</b> 852-2956-0588
	<b>FAX:</b> +44-0-1276-803298	<b>JAPAN FAX:</b> +81-03-3346-784

ACCESS 2P SERVER AND WORKSTATION COMPARISON INFORMATION ONLINE AT [WWW.AMD.COM/SERVERCOMPARISON](http://WWW.AMD.COM/SERVERCOMPARISON) AND [WWW.AMD.COM/WORKSTATIONCOMPARISON](http://WWW.AMD.COM/WORKSTATIONCOMPARISON)



One AMD Place  
Sunnyvale, CA 94088  
(800) 538-8450

©2006 August, Advanced Micro Devices, Inc. All rights reserved. AMD, the AMD Arrow logo, AMD Opteron, AMD PowerNow! and combinations thereof, are trademarks of Advanced Micro Devices, Inc. Microsoft and Windows are registered trademarks of Microsoft Corporation in the United States and/or other jurisdictions. HyperTransport is a licensed trademark of the HyperTransport Technology Consortium. PCI-X is a registered trademark of PCI-SIG. Other names are for information purposes only and may be trademarks of their respective owners. Oracle, JD Edwards, PeopleSoft, and Siebel are registered trademarks of Oracle Corporation and/or its affiliates.