

# The AMD Opteron™ Processor for High-end Embedded Designs

## Providing a balanced approach to embedded system design

The AMD Opteron™ processor provides a breakthrough in high-performance, low power processing for edge-of-enterprise markets including storage and telecommunications, as well as more traditional embedded markets such as security and medical imaging, military systems, and single-board computing.

AMD64 technology with Direct Connect Architecture provides a balanced foundation for embedded systems. Based on the industry-standard x86 platform, AMD64 delivers the right match of processing power, memory performance, I/O throughput, and scalability. Add the vision of 32- and 64-bit application support with native multi-core computing in a consistent thermal envelope and many embedded designers are finding their next-generation systems deliver record-breaking application performance.

## What can a leading processor platform offer?

AMD Opteron processors with Direct Connect Architecture can improve overall system performance and efficiency by helping eliminate traditional bottlenecks inherent in legacy architectures where legacy front-side buses restrict and interrupt the flow of data. With AMD Opteron processors, there are no front-side buses. Instead, the processors, memory, and I/O are directly connected to the CPU and communicate at CPU speed. Further, the integrated memory controller dramatically reduces memory latency while HyperTransport™ technology delivers the industry's highest I/O bandwidth. Data speeds through the system without encountering the traditional front-side bus bottleneck of competing x86 platforms.

In addition to the architectural benefits inherent in Direct Connect Architecture, the AMD Opteron processor offers the following unique advantages for high-end embedded systems:

**HyperTransport technology** provides up to 24.0GB/s peak bandwidth per processor

**On-die integrated memory controller** offers available memory bandwidth up to 10.7GB/s (with DDR2-667) per processor

**Hardware assisted AMD Virtualization™** in AMD Opteron processors with DDR2 helps streamline the efficiency of multiple servers and provides virtual machine memory isolation for improved security

**AMD PowerNow!™ technology** with Optimized Power Management can deliver performance on demand while minimizing power consumption

**DDR2-based platforms** can upgrade to quad-core AMD Opteron processors when they are available in 2007 within existing power and thermal envelopes for significantly better performance-per-watt

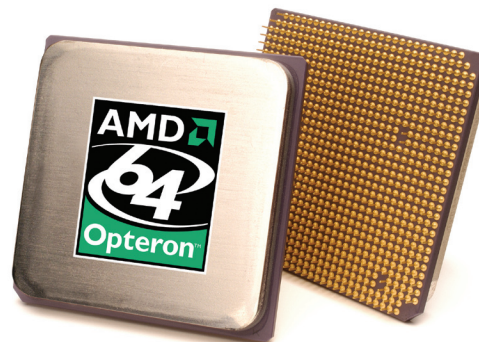

## Reliable, scalable

It's a fact that reliability is key in selecting embedded system components. AMD Opteron processors are NEBS-friendly, supporting telecommunications industry requirements for reliability. AMD64 technology provides features like Error Correcting Code (ECC) and JTAG interfaces for effective debug during system development. Additionally, Direct Connect Architecture requires fewer chips on the motherboard, further enhancing a system's overall reliability.

The AMD Opteron processor provides unique scalability options with glueless multi-processing from one socket (2 core) to 8 socket (16 core) systems. This, combined with AMD64's reliability, helps provide an embedded design that can give customers a long-range plan for the life cycle of their systems.

## Beyond outstanding processors: Longevity, exceptional design support, quick time to market

**The AMD64 Longevity Program** ensures that the high-performance processors you select for an embedded design will be available for a longer than standard time frame. AMD understands the unique requirements of the embedded market and our AMD64 Longevity Program is in place to maximize the available choice of leading-edge x86 processors – delivering a wide range of performance, power, thermal, and packaging features.

AMD has a strong design support program in place. From RDKs to extensive and readily available documentation to a suite of leading debug tools, our goal is to make your design cycle quick and efficient, and to help you get your embedded products on the market quickly. Add this to the improved time to market achieved with utilizing commercial off-the-shelf products like the industry-standard x86 AMD Opteron processor.

# The AMD Opteron™ Processor for High-end Embedded Designs

AMD Opteron™ Processor Model	Wattage	Processor, "Front-side Bus"/Integrated Memory Controller speed*	Socket and Core Specification
8214 HE	68W	2.2GHz	Socket F (1207) Dual Core
8210 EE	45W	1.8GHz	Socket F (1207) Dual Core
865	95W	1.8GHz	Socket 940 Dual Core
852	95W	2.6GHz	Socket 940 Single Core
865 HE	55W	1.8GHz	Socket 940 Dual Core
848 HE	55W	2.2GHz	Socket 940 Single Core
2214 HE	68W	2.2GHz	Socket F (1207) Dual Core
2210 EE	45W	1.8GHz	Socket F (1207) Dual Core
265	95W	1.8GHz	Socket 940 Dual Core
252	95W	2.6GHz	Socket 940 Single Core
265 HE	55W	1.8GHz	Socket 940 Dual Core
248 HE	55W	2.2GHz	Socket 940 Single Core
244 EE	30W	1.8GHz	Socket 940 Single Core
240 EE	30W	1.4GHz	Socket 940 Single Core
1214 HE	68W	2.2GHz	Socket F (1207) Dual Core
1210 EE	45W	1.8GHz	Socket F (1207) Dual Core
165	95W	1.8GHz	Socket 940 Dual Core
152	95W	2.6GHz	Socket 940 Single Core
165 HE	55W	1.8GHz	Socket 940 Dual Core
148 HE	55W	2.2GHz	Socket 940 Single Core
144 EE	30W	1.8GHz	Socket 940 Single Core

\*With AMD64 Technology, the processor-to-memory controller interface is on the die, allowing memory data to flow at processor speed. In multi-processor systems, each processor has its own memory controller, allowing for scalability without an increase in data bottlenecks.

AMD Opteron™ Processor Design for Socket F (1207)

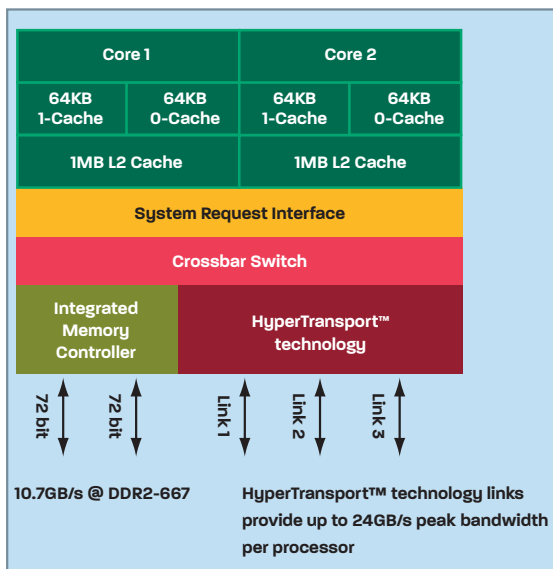

## What about performance-per-watt?

It's a growing concern from the data center to embedded systems – how to increase computing performance without incurring excess power draw, additional cooling requirements, or taking up more space in either real estate or form factor. AMD was first to recognize that the processor could offer part of the solution in reducing total cost of ownership.

- Microprocessor architecture – AMD64 processor design helps reduce the overall system power budget with integration of the North Bridge, while multi-core processors offer increased performance, with higher compute density and scalability
- Low power processors – AMD provides a stable, consistent roadmap with a variety of wattage options
- Low operational costs – reduced power draw and heat dissipation means lower data center energy costs. Features like AMD PowerNow!™ technology with Optimized Power Management delivers performance on demand and minimizes power consumption
- AMD Opteron processors with DDR2 offer a seamless upgrade path to quad-core computing in the same power and thermal envelope

## About AMD

AMD (NYSE:AMD) designs and produces innovative microprocessors and low-power processor solutions for the computer, communications, and consumer electronics industries. AMD is dedicated to delivering standards-based, customer-focused solutions for technology users, ranging from enterprises and governments to individual consumers.

[www.amd.com](http://www.amd.com)

One AMD Place  
P.O. Box 3453

Sunnyvale, CA 94088-3453, USA

Tel: 408-749-4000 or 800-538-8450

TWX: 910-339-9280

TELEX: 34-6306

42350A

## Technical Support

USA & Canada: 800-222-9323, Opt 2 or 408-749-5703

USA & Canada PC Processors Only: 408-749-3060

USA & Canada E-mail: [hw.support@amd.com](mailto:hw.support@amd.com)

Latin America E-mail (Spanish): [amdsp@vermont.com.br](mailto:amdsp@vermont.com.br)

Latin America E-mail (Portuguese): [amdbp@vermont.com.br](mailto:amdbp@vermont.com.br)

Argentina: 0800-333-0219

Brazil: 0800-557686

Chile: 123-00-209-110

Mexico: 01-800-123-4709

Europe & UK: +44-0-1276-803299

Europe & UK Fax: +44-0-1276-803298

France: 0800-908-621

Germany: +49-89-450-53199

Italy: 800-877224

Europe E-mail: [euro.tech@amd.com](mailto:euro.tech@amd.com)

China Fax: 86-10-8518-1777

Hong Kong Fax: 852-2956-0588

Japan Fax: 81-3-3346-7848

Korea Fax: 82-2-3468-2601

Taiwan Fax: 886-2-2655-7855

Asia E-mail: [asia.support@amd.com](mailto:asia.support@amd.com)

## Literature Ordering

On the Web: [www.amd.com/support/literature.html](http://www.amd.com/support/literature.html)

USA & Canada: 800-222-9323, Opt 1

USA & Canada E-mail: [amd\\_literature@comac.com](mailto:amd_literature@comac.com)

Europe E-mail: [euro.lit@amd.com](mailto:euro.lit@amd.com)

China Fax: 86-10-8518-1777

Hong Kong Fax: 852-2956-0588

Japan Fax: 81-3-3346-7848

Taiwan Fax: 886-2-2655-7855

©2007 Advanced Micro Devices, Inc. All rights reserved.

AMD, the AMD Arrow Logo, AMD Opteron, and combinations thereof, and AMD PowerNow! are trademarks of Advanced Micro Devices, Inc. HyperTransport is a licensed trademark of the HyperTransport Technology Consortium. Other names are for informational purposes only and may be trademarks of their respective owners.

**AMD**  
Smarter Choice