

Each part has 2 additional fields: AssyOpt1 and AssyOpt2. If AssyOpt1=1 then this part should be assembled when using the PHY as the LED drivers. If AssyOpt2=1 then this part should be assembled when using the GT4810A with the PLD as the LED driver. Parts with AssyOptx=0 are not assembled. When BOM is generated, ass {AssyOpt1} or {AssyOpt2} to the field list, a '0' or '1' the the right of each part will tell if this part should be assembled.

Designed by CompuLab Ltd. 972 4 8238567

Title			GT48310A RMII EV with AMD NetPHY-4LP		
Size	Document Number		MAIN		
B			Rev 1.0		
Date:	Monday, August 09, 1999	Sheet	1	of	17



GT48310A PART2 OF 2

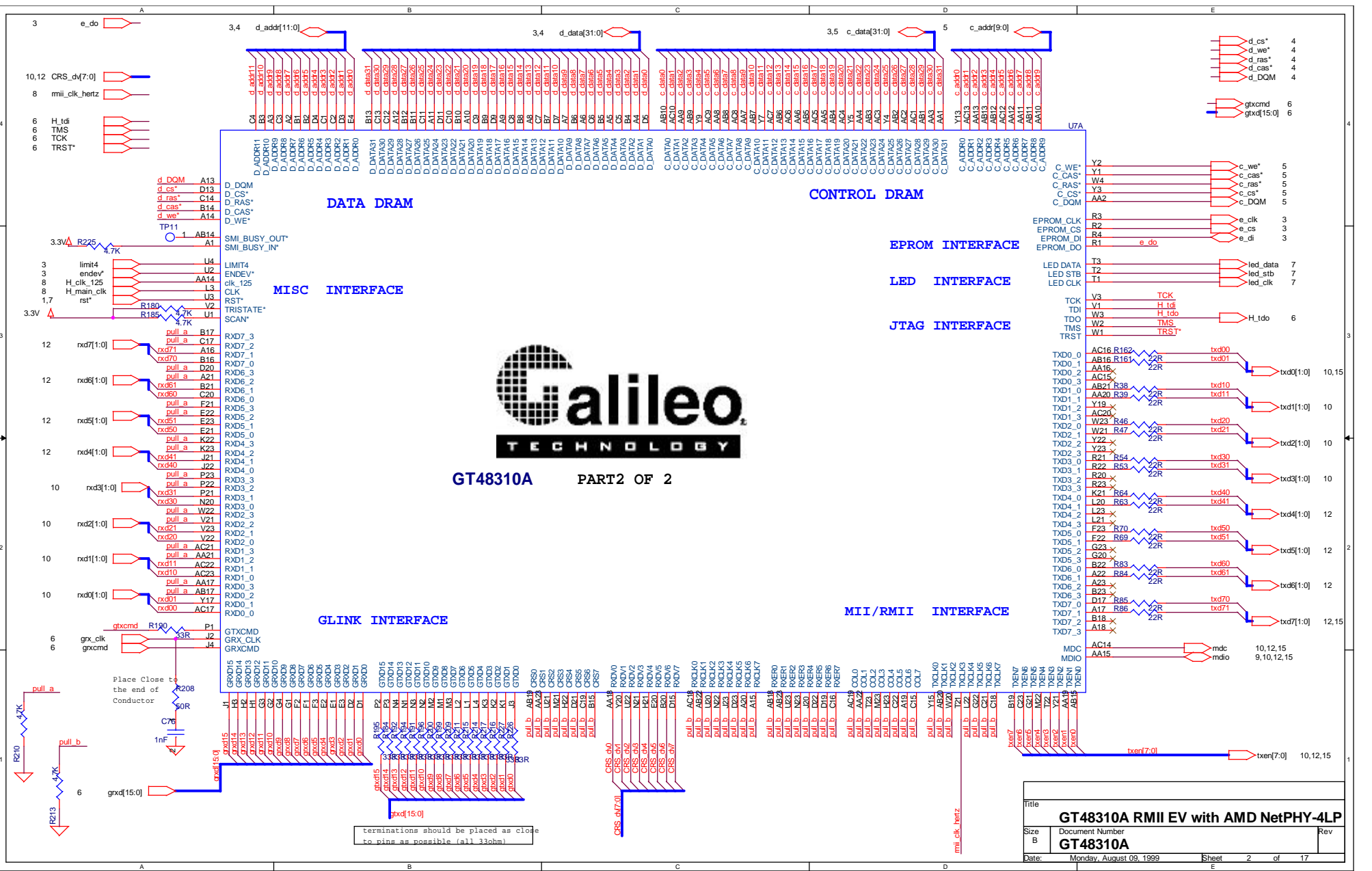

terminations should be placed as close to pins as possible (all 33ohm)

Title		
GT48310A RMII EV with AMD NetPHY-4LP		
Size	Document Number	Rev
B	GT48310A	
Date:	Monday, August 09, 1999	Sheet 2 of 17

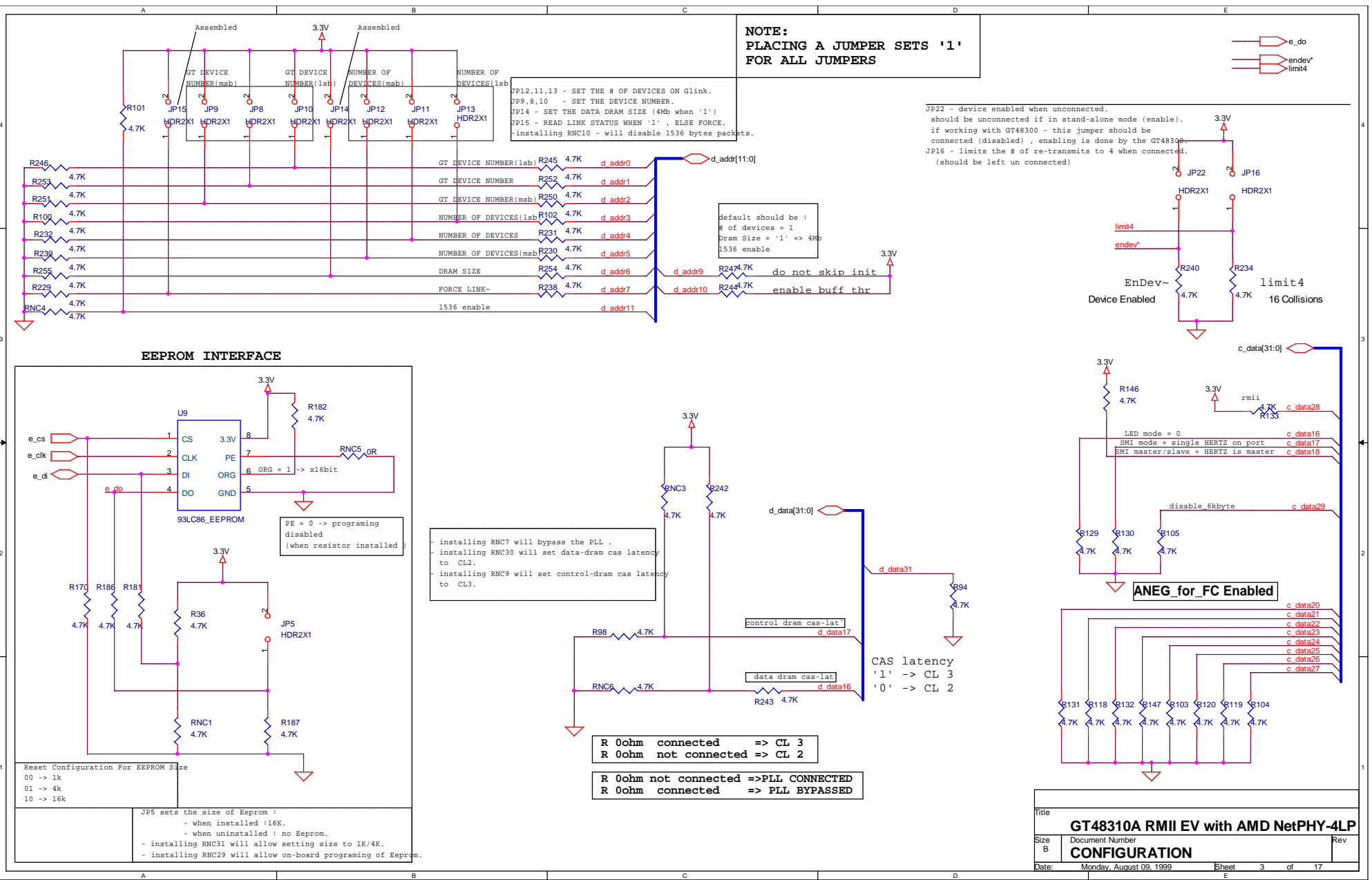

**NOTE:
PLACING A JUMPER SETS '1'
FOR ALL JUMPERS**

JP12,11,13 - SET THE # OF DEVICES ON Glink.
 JP9,8,10 - SET THE DEVICE NUMBER.
 JP14 - SET THE DATA DRAM SIZE (4mb when '1')
 JP15 - READ LINK STATUS WHEN '1', ELSE FORCE.
 -installing RNC10 - will disable 1536 bytes packets.

Default should be :
 # of devices = 1
 Dram Size = '1' => 4Mb
 1536 enable

JP22 - device enabled when unconnected.
 should be unconnected if in stand-alone mode (enable).
 if working with GT48300 - this jumper should be
 connected (disabled), enabling is done by the GT48300.
 JP16 - limits the # of re-transmits to 4 when connected.
 (should be left un connected)

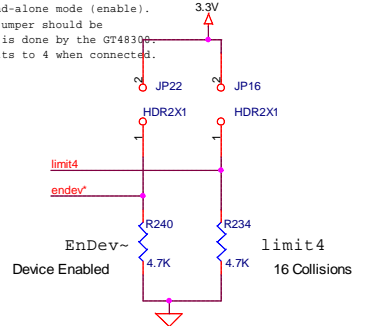
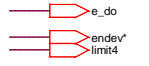

EEPROM INTERFACE

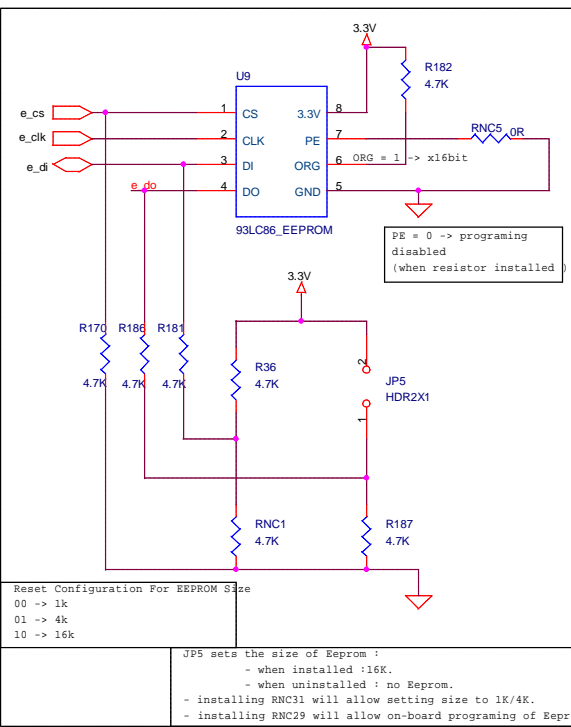

- installing RNC7 will bypass the PLL .
 - installing RNC30 will set data-dram cas latency to CL2.
 - installing RNC9 will set control-dram cas latency to CL3.

R 0ohm connected => CL 3
 R 0ohm not connected => CL 2

R 0ohm not connected =>PLL CONNECTED
 R 0ohm connected => PLL BYPASSED

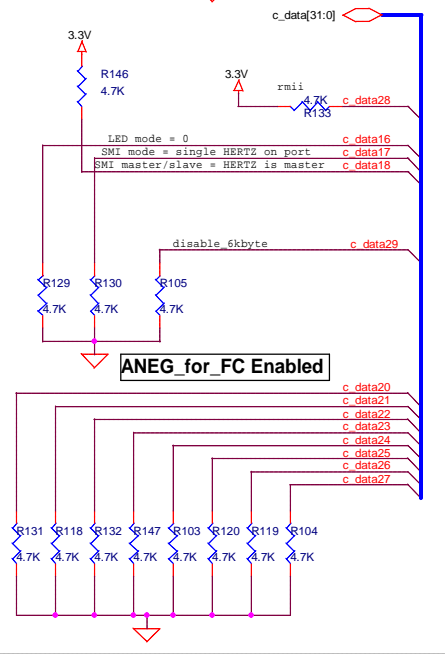

Title			
GT48310A RMII EV with AMD NetPHY-4LP			
Size	Document Number	Rev	
B	CONFIGURATION		
Date:	Monday, August 09, 1999	Sheet	3 of 17

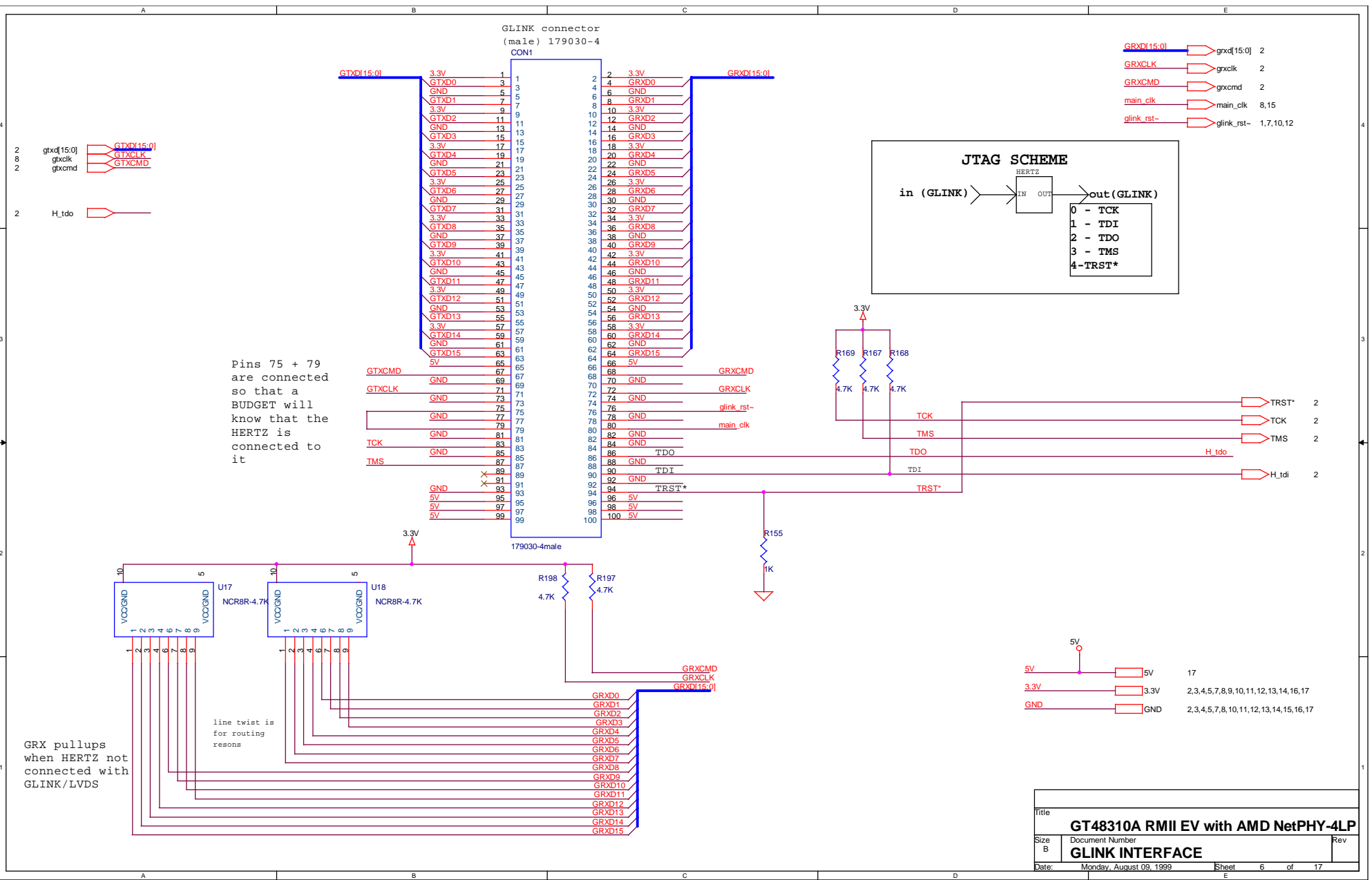

Title		
GT48310A RMII EV with AMD NetPHY-4LP		
Size	Document Number	Rev
B	GLINK INTERFACE	
Date:	Monday, August 09, 1999	Sheet 6 of 17

rst* 1,2,15

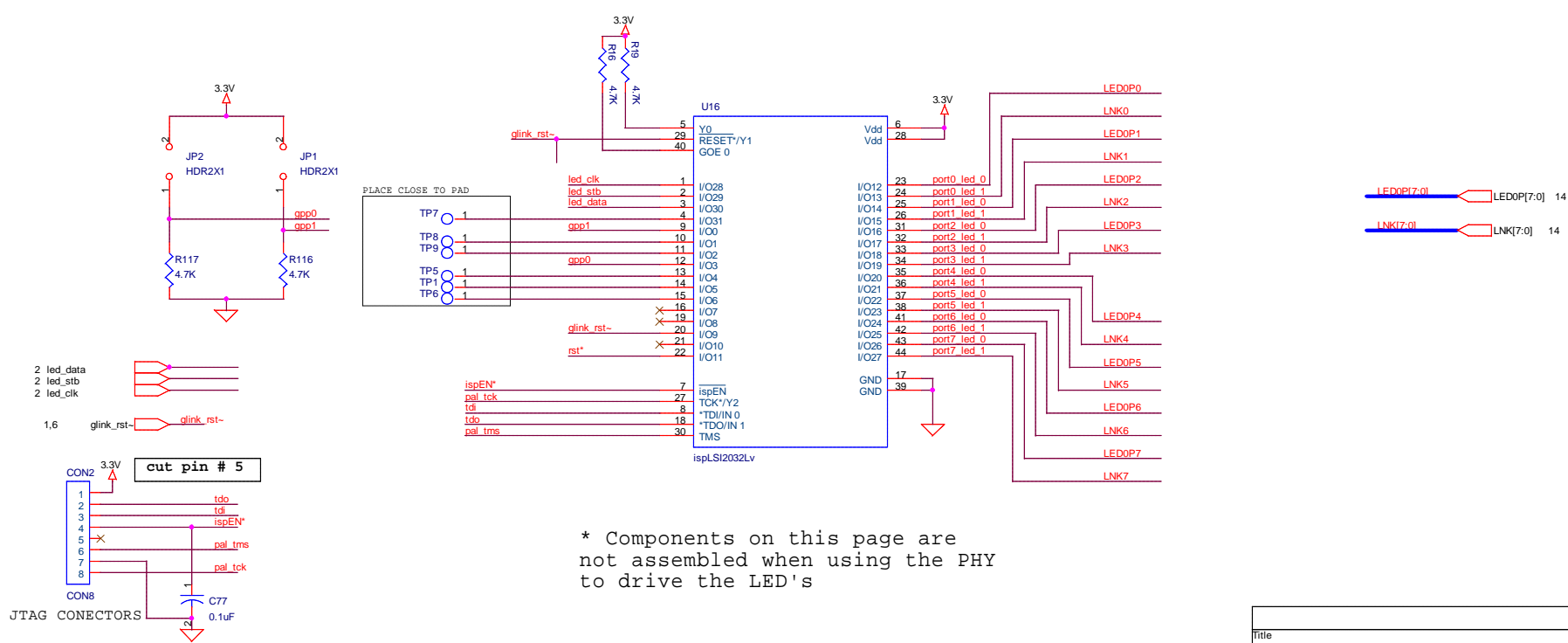

* Components on this page are not assembled when using the PHY to drive the LED's

Title		
GT48310A RMII EV with AMD NetPHY-4LP		
Size	Document Number	Rev
B	LED_Controller	
Date:	Monday, August 09, 1999	Sheet 7 of 17

CLOCK ROUTING (see recommendations):

- 1.SERIES DUMPING RESISTORS SHOULD BE PLACED AS CLOSE AS POSSIBLE TO OUTPUTS.
- 2.CLK TRACES SHOULD NOT INTERSECT EACH OTHER .
- 3.TRY TO ROUTE CLK ON SINGLE LAYER.
- 4.DO NOT USE 90deg ANGLES .
- 5."WRAP" CLK SIGNALS WITH GND/POWER.

MAIN CLOCK

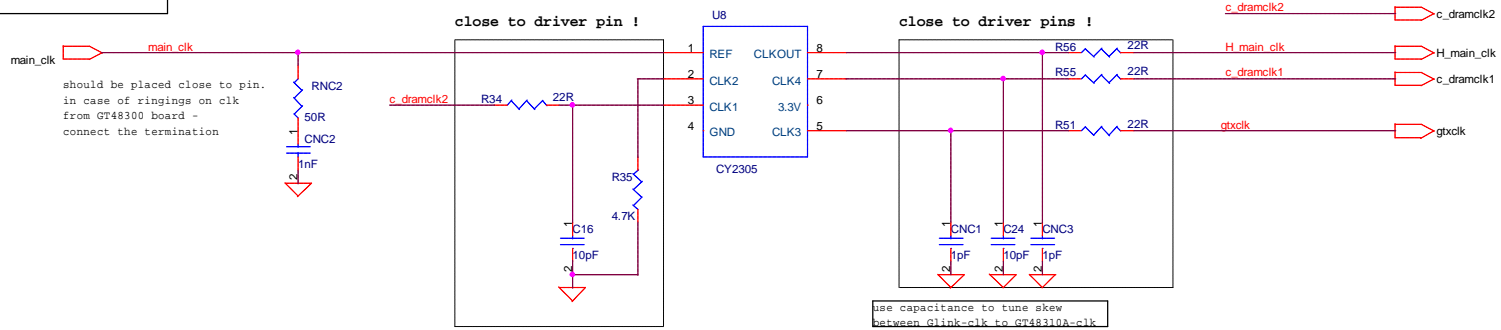

RMII : 50Mhz.

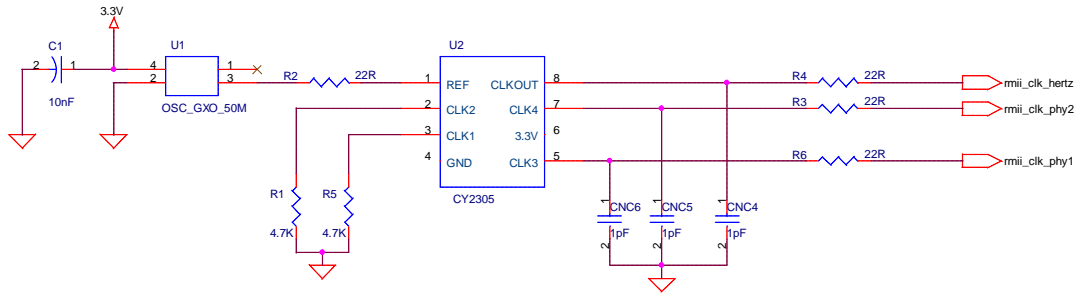

***Data Dram clk (125M)**

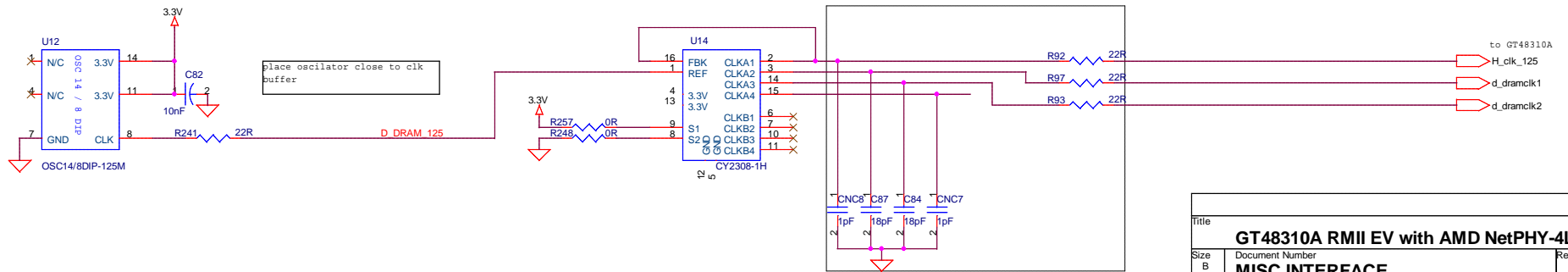

Title		
GT48310A RMII EV with AMD NetPHY-4LP		
Size	Document Number	Rev
B	MISC INTERFACE	
Date:	Monday, August 03, 1999	Sheet 8 of 17

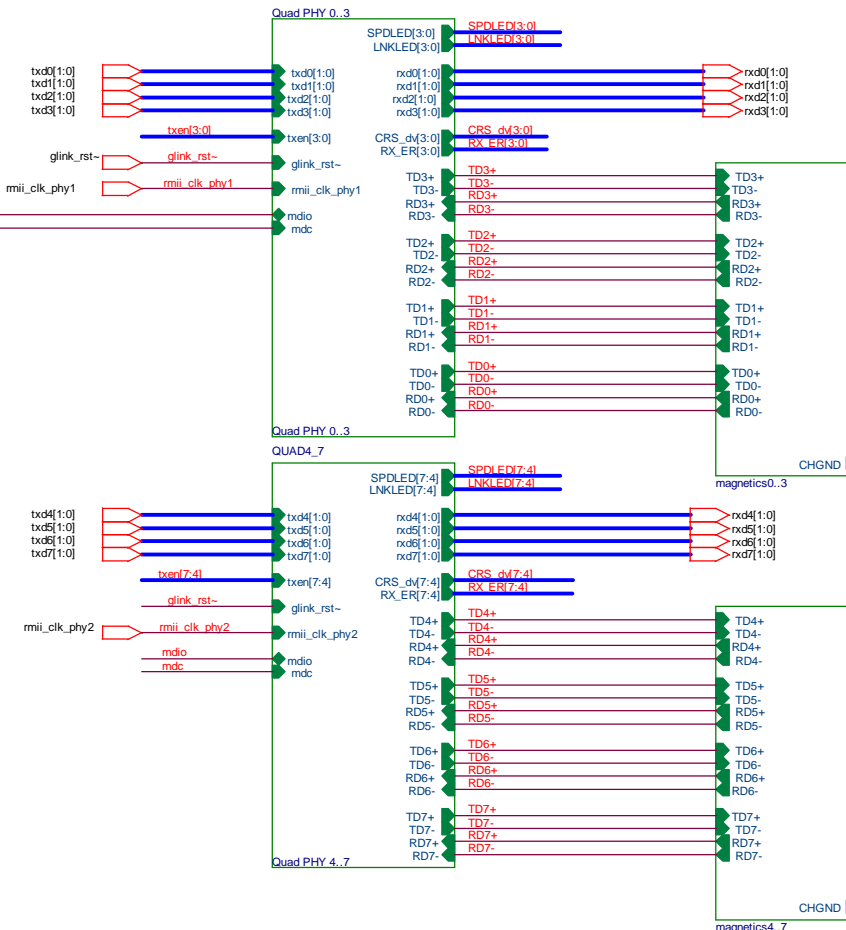
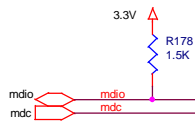

can also use : XFAT M8Q14 as magnetics .

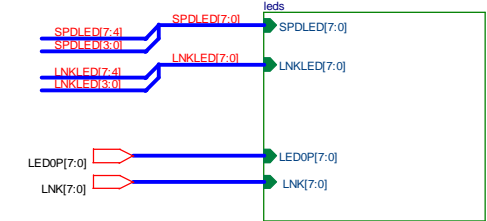
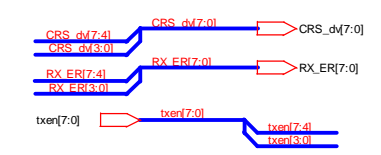

place capacitors/coil for coupling chassis ground to system gnd.

RJ45 - front view

1	3	5	7
0	2	4	6

Title		
GT48310A RMII EV with AMD NetPHY-4LP		
Size	Document Number	Rev
B	RMII INTERFACE	
Date:	Monday, August 09, 1999	Sheet 9 of 17

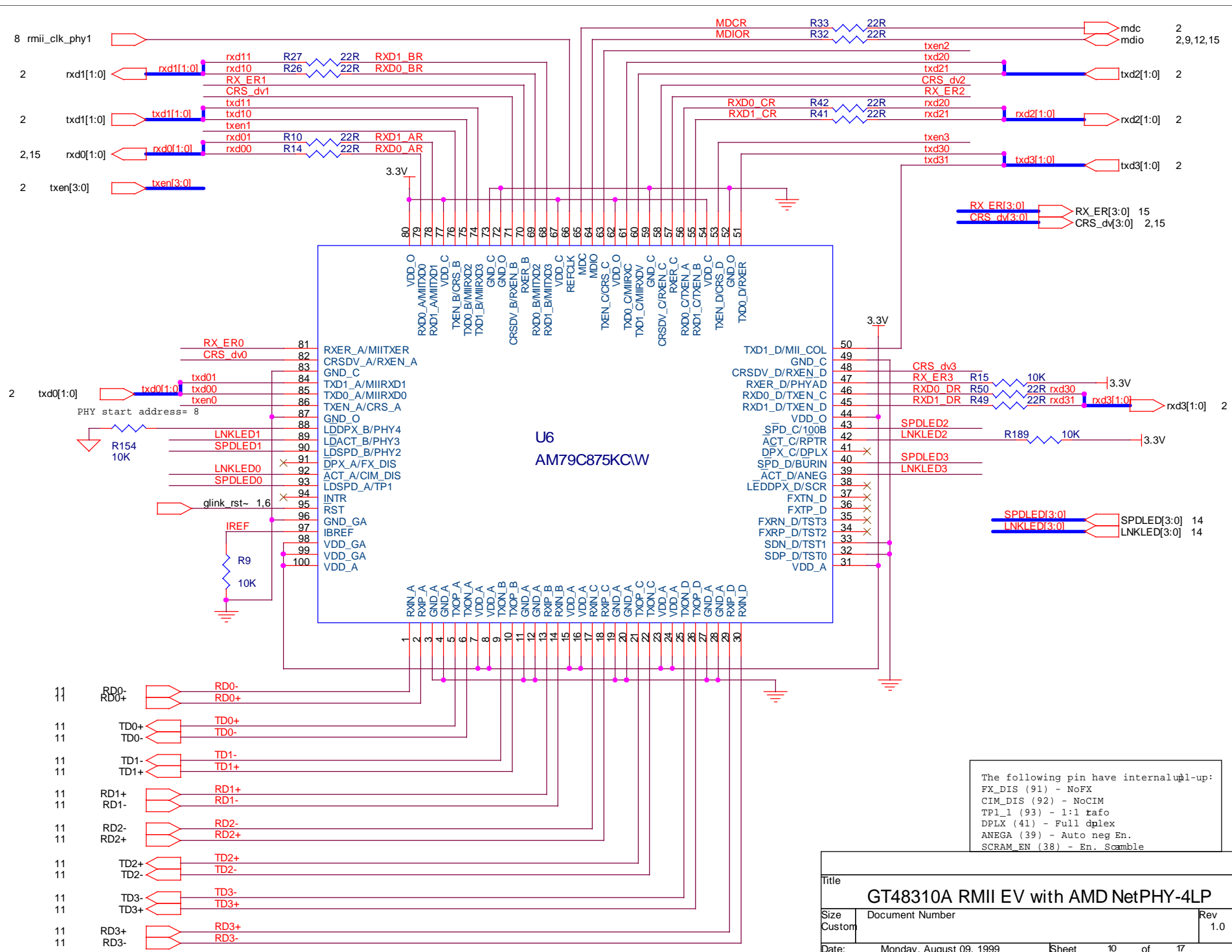

The following pin have internal pull-up:
 FX_DIS (91) - NoFX
 CIM_DIS (92) - NoCIM
 TP1_1 (93) - 1:1 fafo
 DPLX (41) - Full duplex
 ANEGA (39) - Auto neg En.
 SCRAM_EN (38) - En. Scramble

Title		
GT48310A RMIi EV with AMD NetPHY-4LP		
Size	Document Number	Rev
Custom		1.0
Date:	Monday, August 09, 1999	Sheet 10 of 17

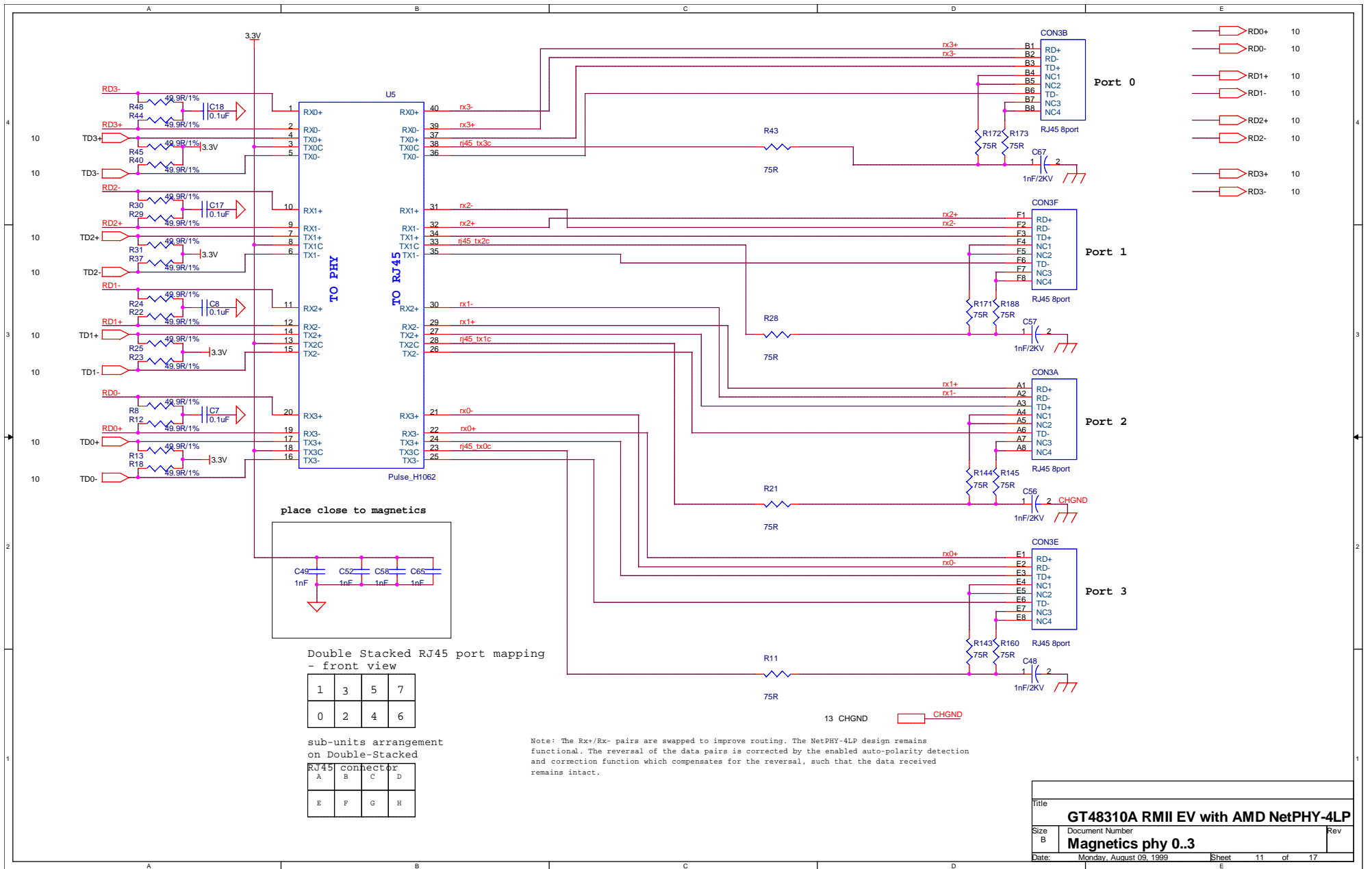

Title			
GT48310A RMII EV with AMD NetPHY-4LP			
Size	Document Number		Rev
B	Magnetics phy 0.3		
Date:	Monday, August 09, 1999	Sheet	11 of 17

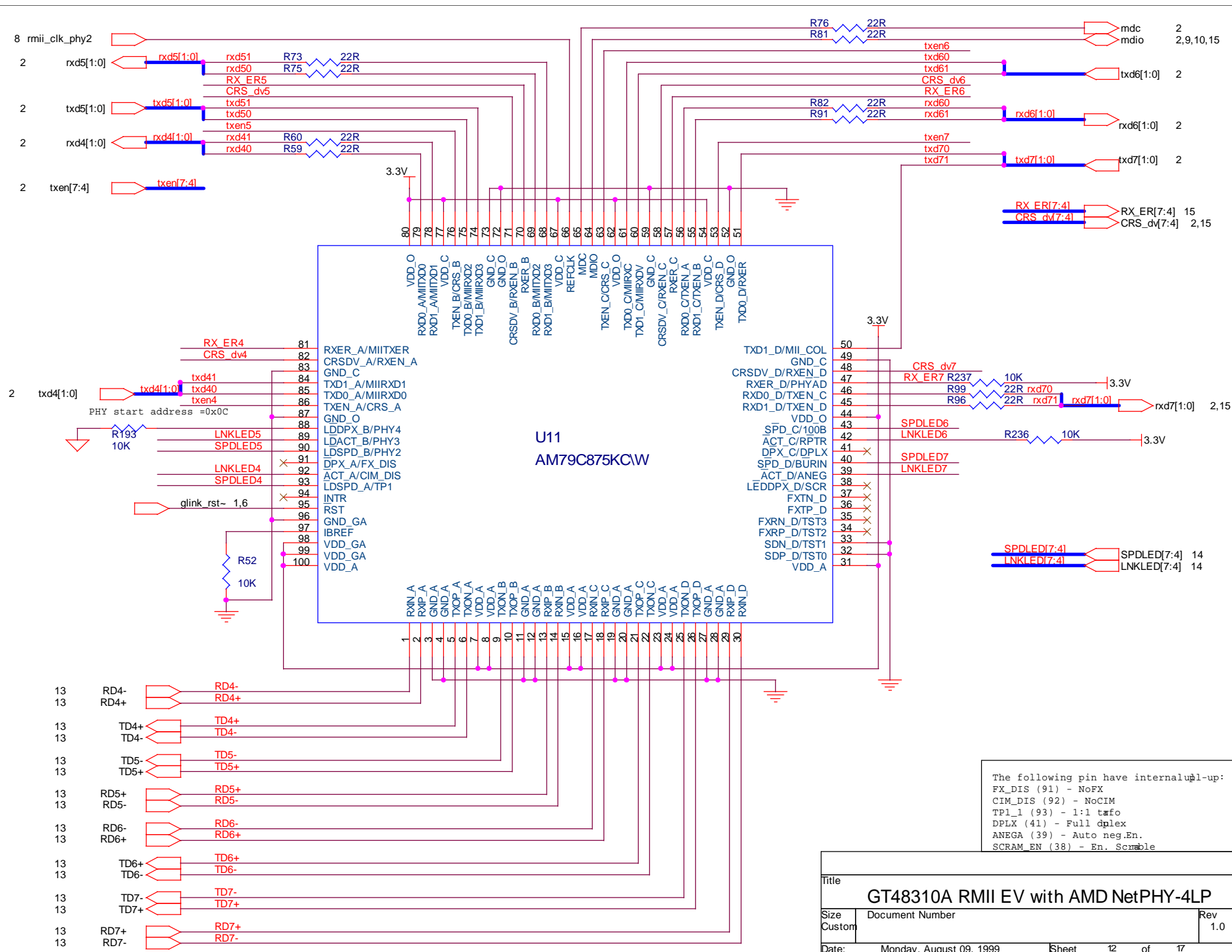

The following pin have internal pull-up:

- FX_DIS (91) - NoFX
- CIM_DIS (92) - NoCIM
- TP1_1 (93) - 1:1 tafo
- DPLX (41) - Full duplex
- ANEGA (39) - Auto neg.En.
- SCRAM_EN (38) - En. Scramble

Title		
GT48310A RMIi EV with AMD NetPHY-4LP		
Size	Document Number	Rev
Custom		1.0
Date:	Monday, August 09, 1999	Sheet 12 of 17

11 CHGND CHGND

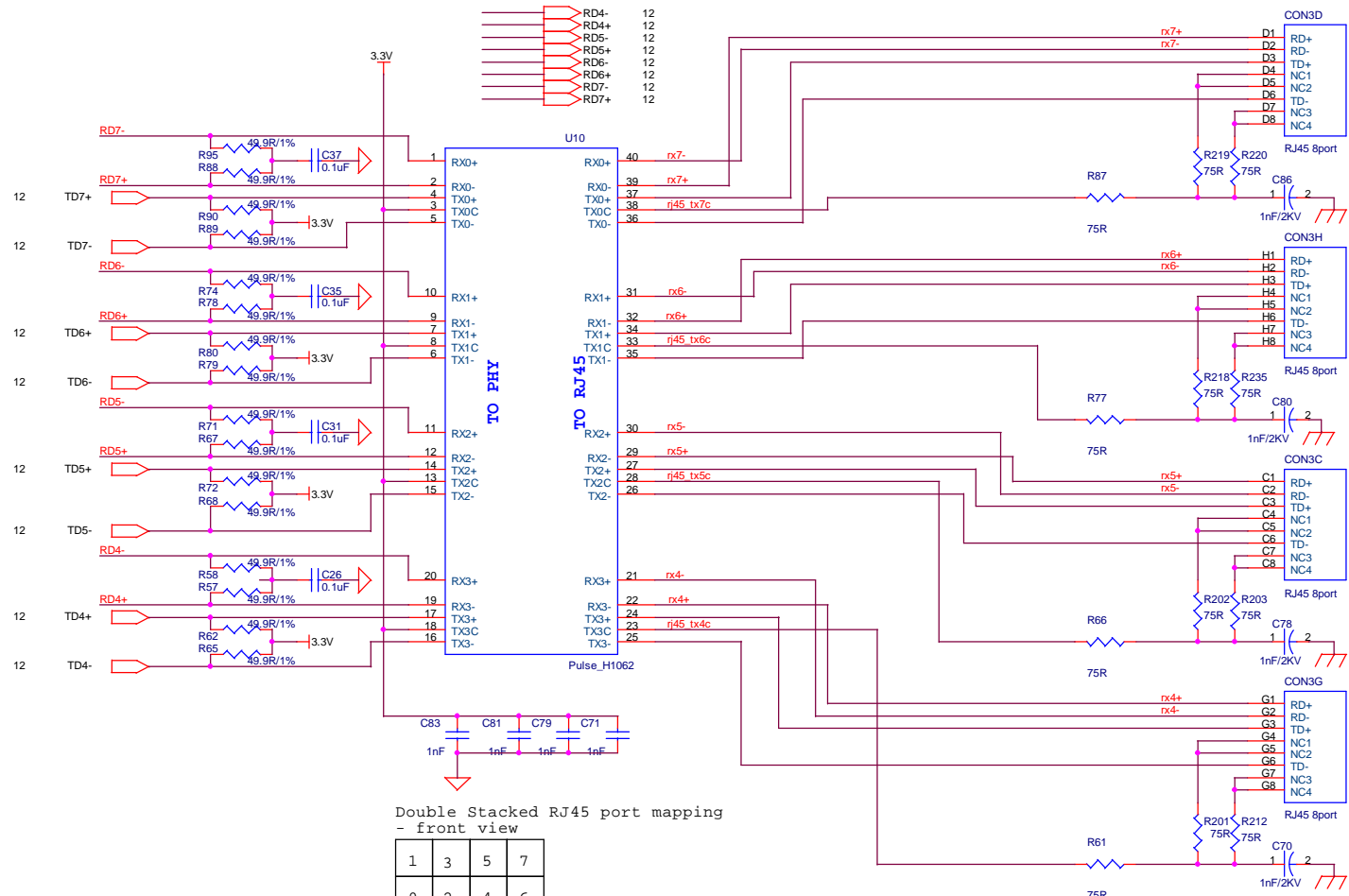
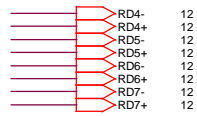

Double Stacked RJ45 port mapping - front view

1	3	5	7
0	2	4	6

sub-units arrangement on Double-Stacked

RJ45 connector			
A	B	C	D
E	F	G	H

Note: The Rx+/Rx- pairs are swapped to improve routing. The NetPHY-4LP design remains functional. The reversal of the data pairs is corrected by the enabled auto-polarity detection and correction function which compensates for the reversal, such that the data received remains intact.

Title			GT48310A RMII EV with AMD NetPHY-4LP		
Size	Document Number				Rev
B	Magnetics phy 4..7				
Date:	Monday, August 09, 1999	Sheet	13	of	17

LEDOP[7:0] indicate SPEED when driven by PHY.
 LNK[7:0] indicate DUPLEX when driven by GT48310A.

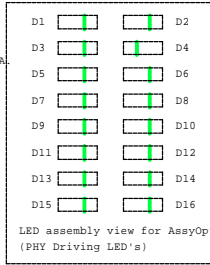

* Disassemble when using the PHY as the LED driver.
 * Assemble when using the GT48310A as the LEDdriver.
 SPDLED1 10K R126

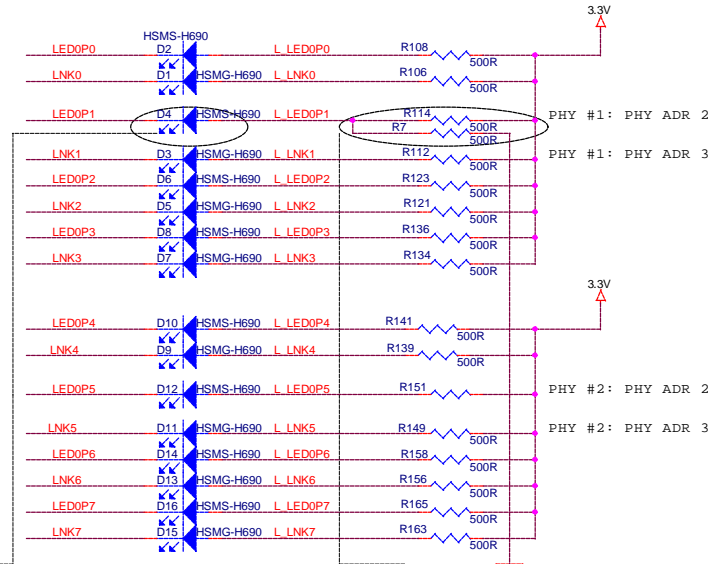
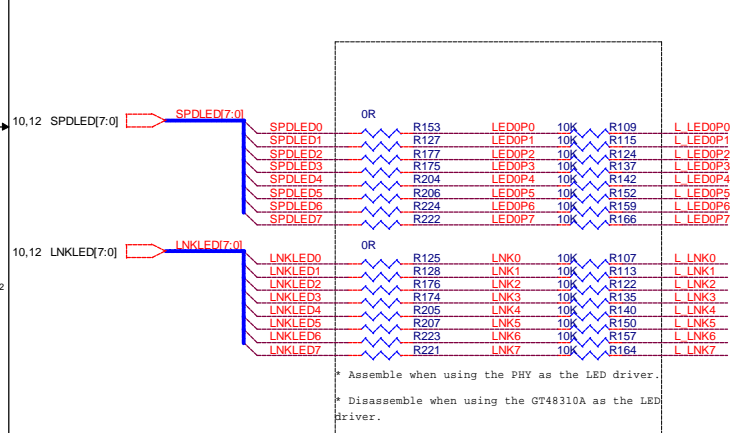

7	6	5	4	3	2	1	0
7	6	5	4	3	2	1	0

Leds CS View

LED polarity changes according to driving source:
 - Cathode to the left when driven by the GT48310A.
 - Anode to the left when driven by the PHY.

Assemble the resistor that matches LED polarity

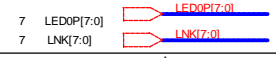

Title		
GT48310A RMII EV with AMD NetPHY-4LP		
Size B	Document Number	Rev
LEDS		
Date:	Monday, August 09, 1999	Sheet 14 of 17

GND GND

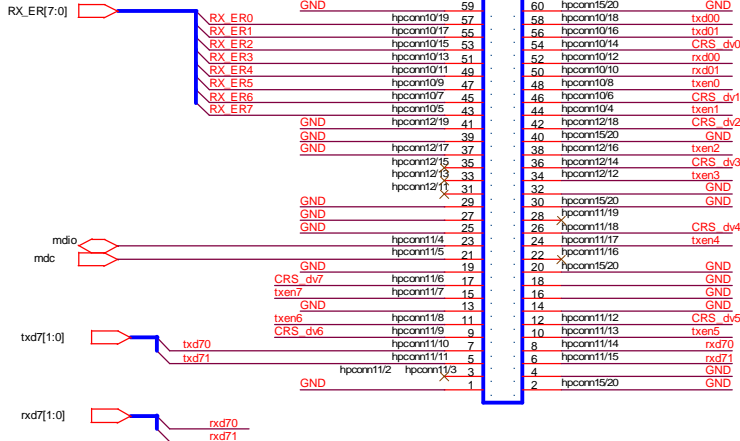
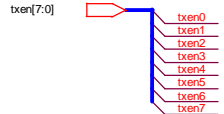
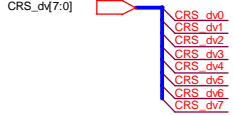
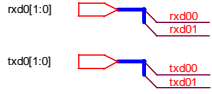
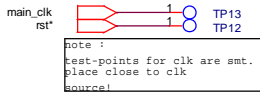

Title		
GT48310A RMII EV with AMD NetPHY-4LP		
Size	Document Number	Rev
B	TEST POINTS	
Date:	Monday, August 09, 1999	Sheet 15 of 17

2,3,4,5,6,7,8,10,11,12,13,14,15,17 GND
 2,3,4,5,6,7,8,9,10,11,12,13,14,17 3.3V

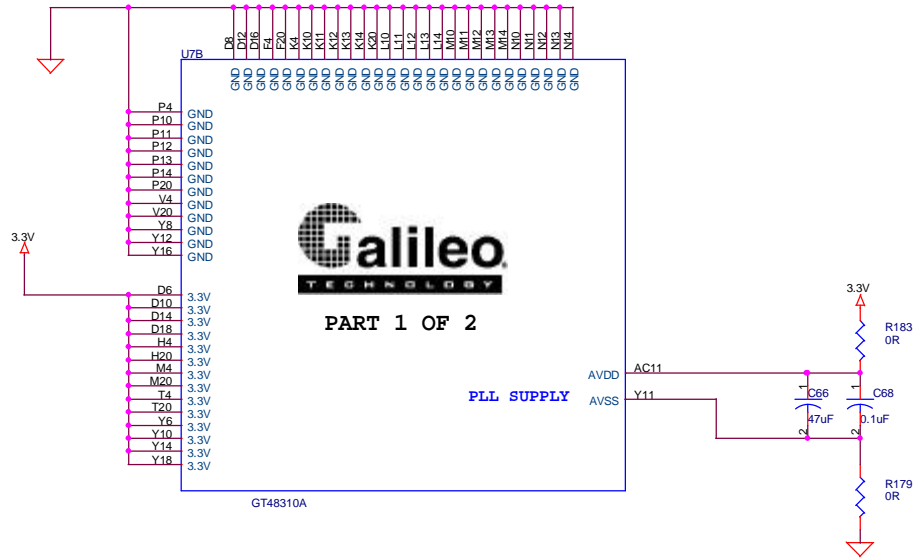
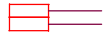

Title		
GT48310A RMII EV with AMD NetPHY-4LP		
Size	Document Number	Rev
B	GT48310-POWER BLOCK	
Date:	Monday, August 09, 1999	Sheet 16 of 17

2,3,4,5,6,7,8,9,10,11,12,13,14,16 3.3V
 6 5V
 2,3,4,5,6,7,8,10,11,12,13,14,15,16 GND

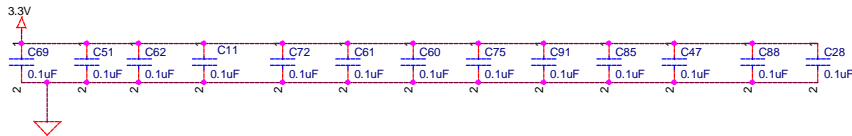
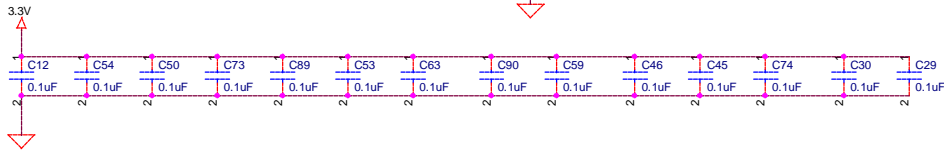
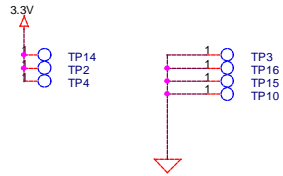
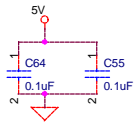
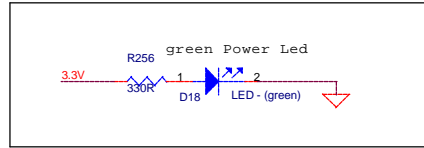

NOTE : PUT AS MANY VIAS AS POSSIBLE BETWEEN TWO GROUND LAYERS .

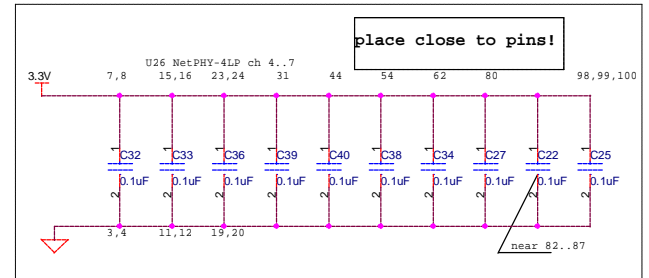
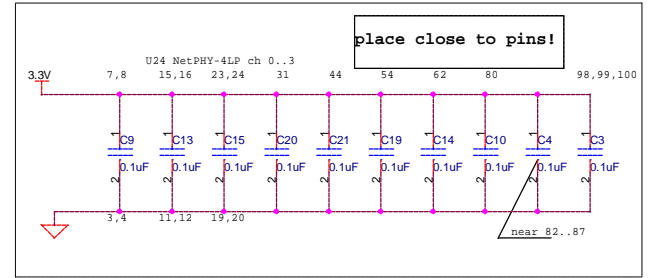
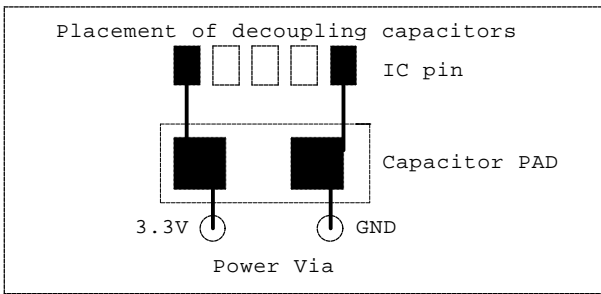
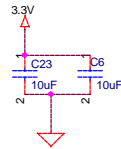

place according to filter-schem!

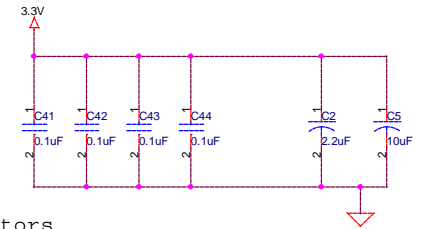

PHY capacitors

Title		
GT48310A RMII EV with AMD NetPHY-4LP		
Size	Document Number	Rev
B	POWER	
Date:	Monday, August 09, 1999	Sheet 17 of 17

ADVANCED MICRO DEVICES
 Designed by CompuLab Ltd. 972 4 8238567

Bill Of Materials August 9,1999 13:04:22 Angel

Item	Quantity	Reference	Part	Assembly	Option	1
1	7	CNC1,CNC3,CNC4,CNC5,CNC6,	1pF		0	
		CNC7,CNC8				
2	1	CNC2	1nF		0	
3	1	CON_NC1	104652-6		1	
4	1	CON1	179030-4male		1	
5	1	CON2	CON8		1	
6	1	CON3	RJ45 8port		1	
7	2	C82,C1	10nF		1	
8	1	C2	2.2uF		1	
9	63	C3,C4,C7,C8,C9,C10,C11,C12,C13,C14,C15,C17,C18,	0.1uF		1	
		C19,C20,C21,C22,C25,C26,				
		C27,C28,C29,C30,C31,C32,				
		C33,C34,C35,C36,C37,C38,				
		C39,C40,C41,C42,C43,C44,				
		C45,C46,C47,C50,C51,C53,				
		C54,C55,C59,C60,C61,C62,				
		C63,C64,C68,C69,C72,C73,				
		C74,C75,C77,C85,C88,C89,				
		C90,C91				
10	3	C5,C6,C23	10uF		1	
11	2	C24,C16	10pF		1	
12	8	C48,C56,C57,C67,C70,C78,	1nF/2KV		1	
		C80,C86				
13	9	C49,C52,C58,C65,C71,C76,	1nF		1	
		C79,C81,C83				
14	1	C66	47uF		1	
15	2	C84,C87	18pF		1	
16	8	D1,D3,D5,D7,D9,D11,D13,HSMG-H690			1	
		D15				
17	8	D2,D4,D6,D8,D10,D12,D14,	HSMS-H690		1	
		D16				
18	1	D18	LED - (green)		1	
19	13	JP1,JP2,JP5,JP8,JP9,JP10,	HDR2X1		1	
		JP11,JP12,JP13,JP14,JP15,				
		JP16,JP22				
20	4	RNC1,RNC3,RNC4,RNC6	4.7K		0	
21	1	RNC2	50R		0	
22	1	RNC5	0R		0	
23	69	R1,R5,R16,R19,R20,R35,	4.7K		1	
		R36,R94,R98,R100,R101,				
		R102,R103,R104,R105,R110,				
		R111,R116,R117,R118,R119,				
		R120,R129,R130,R131,R132,				
		R133,R138,R146,R147,R148,				
		R167,R168,R169,R170,R180,				
		R181,R182,R185,R186,R187				

		R197,R198,R210,R213,R225, R228,R229,R230,R231,R232, R233,R234,R238,R239,R240, R242,R243,R244,R245,R246, R247,R249,R250,R251,R252, R253,R254,R255		
24	48	R2,R3,R4,R6,R10,R14,R26, R27,R32,R33,R34,R38,R39, R41,R42,R46,R47,R49,R50, R51,R53,R54,R55,R56,R59, R60,R63,R64,R69,R70,R73, R75,R76,R81,R82,R83,R84, R85,R86,R91,R92,R93,R96, R97,R99,R161,R162,R241	22R	1
25	16	R7,R106,R108,R112,R121,500R R123,R134,R136,R139,R141, R149,R151,R156,R158,R163, R165		1
26	32	R8,R12,R13,R18,R22,R23,49.9R/1% R24,R25,R29,R30,R31,R37, R40,R44,R45,R48,R57,R58, R62,R65,R67,R68,R71,R72, R74,R78,R79,R80,R88,R89, R90,R95		1
27	24	R9,R15,R52,R107,R109, R113,R115,R122,R124,R135, R137,R140,R142,R150,R152, R154,R157,R159,R164,R166, R189,R193,R236,R237	10K	1
28	24	R11,R21,R28,R43,R61,R66, R77,R87,R143,R144,R145, R160,R171,R172,R173,R188, R201,R202,R203,R212,R218, R219,R220,R235	75R	1
29	21	R17,R125,R127,R128,R153, R174,R175,R176,R177,R179, R183,R204,R205,R206,R207, R221,R222,R223,R224,R248, R257	0R	1
30	1	R114 500R	0	
31	1	R126 10K	0	
32	1	R155 1K	1	
33	1	R178 1.5K	1	
34	17	R184,R190,R191,R192,R194, R195,R196,R199,R200,R209, R211,R214,R215,R216,R217, R226,R227	33R	1
35	1	R208 50R	1	
36	1	R256 330R	1	
37	9	TP1,TP5,TP6,TP7,TP8,TP9, TP11,TP12,TP13	TPsmd1x1	0
38	7	TP2,TP3,TP4,TP10,TP14, TP_TH TP15,TP16	0	
39	1	U1 OSC_GXO_50M	1	
40	2	U2,U8 CY2305	1	
41	2	U3,U4 MT48LC1M161A1TG-81		
42	2	U10,U5 Pulse_H1062	1	
43	2	U11,U6 AM79C875KC\W		1
44	1	U7 GT48310A	1	
45	1	U9 93LC86_EEPROM		1
46	1	U12 OSC14/8DIP-125		1

47	2	U15,U13	MT48LC1M161A1TG-71
48	1	U14	CY2308-1H 1
49	1	U16	ispLSI2032Lv 0
50	2	U17,U18	NCR8R-4.7K 1