

Am29LV400B

Known Good Wafer

Data Sheet



July 2003

The following document specifies Spansion memory products that are now offered by both Advanced Micro Devices and Fujitsu. Although the document is marked with the name of the company that originally developed the specification, these products will be offered to customers of both AMD and Fujitsu.

Continuity of Specifications

There is no change to this datasheet as a result of offering the device as a Spansion product. Any changes that have been made are the result of normal datasheet improvement and are noted in the document revision summary, where supported. Future routine revisions will occur when appropriate, and changes will be noted in a revision summary.

Continuity of Ordering Part Numbers

AMD and Fujitsu continue to support existing part numbers beginning with "Am" and "MBM". To order these products, please use only the Ordering Part Numbers listed in this document.

For More Information

Please contact your local AMD or Fujitsu sales office for additional information about Spansion memory solutions.

Publication Number **26609** Revision **B** Amendment **+0** Issue Date **April 18, 2003**



Am29LV400B Known Good Wafer

4 Megabit (512 K x 8-Bit/256 K x 16-Bit)

CMOS 3.0 Volt-only, Boot Sector Flash Memory, Die Revision 1

Note: This supplement contains information on the Am29LV400B in Known Good Wafer form. Refer to the Am29LV400B standard datasheet (publication 21523) for full electrical specifications.

DISTINCTIVE CHARACTERISTICS

- Top or bottom boot block configurations available
 - Minimum 1,000,000 write cycle guarantee per sector
 - 20-year data retention at 125°C
 - Tested to datasheet specifications at temperature
 - Quality and reliability levels equivalent to standard packaged components
 - Complies with JEDEC standards for wafer shipments
-

GENERAL DESCRIPTION

The Am29LV400B in Known Good Wafer (KGW) form is an 4 Mbit, 3.0 volt-only Flash memory. AMD defines KGW as standard product in wafer form, tested for functionality and speed. AMD KGW products have the same reliability and quality as AMD products in packaged form.

Electrical Specifications

Refer to the Am29LV400B data sheet, publication number 21523, for full electrical specifications on the Am29LV400B in KGW form.

PRODUCT SELECTOR GUIDE

Family Part Number	Am29LV400B KGW					
Speed Option & Voltage Operating Range, V _{CC}	3.0 – 3.6 V	-60R				
	2.7 – 3.6 V		-70	-80	-90	-120
Max Access Time, t _{ACC} (ns)		60	70	80	90	120
Max CE# Access, t _{CE} (ns)		60	70	80	90	120
Max OE# Access, t _{OE} (ns)		30	30	30	35	50

Note: Refer to "Test Conditions" for additional information related to speed options.

DIE PHOTOGRAPH

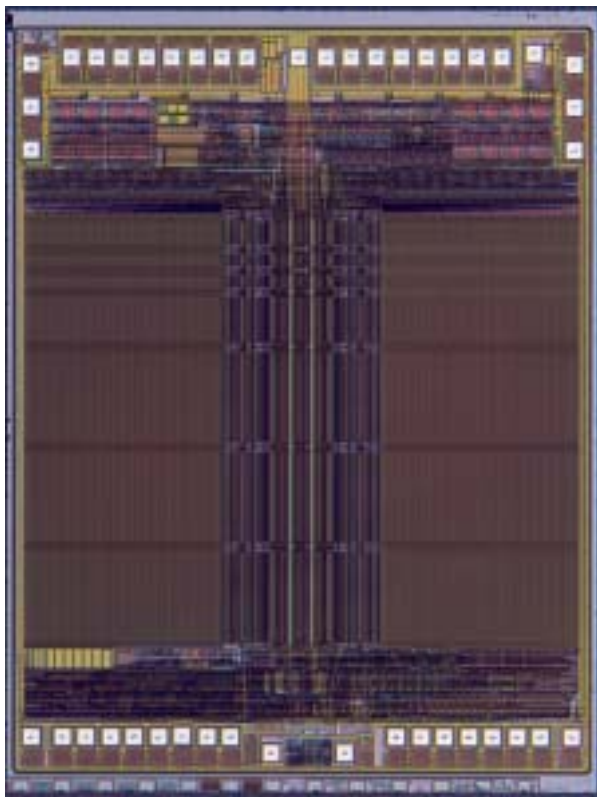

DIE PAD LOCATIONS

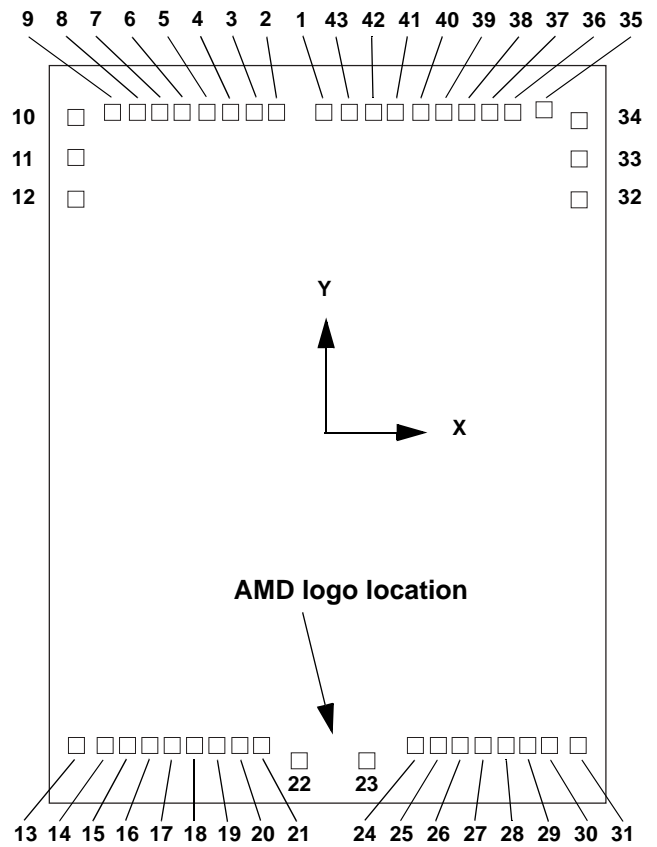

PAD DESCRIPTION

Pad locations relative to die center.

Pad	Signal	Pad Center (mils)		Pad Center (millimeters)	
		X	Y	X	Y
1	V _{CC}	-0.90	80.50	-0.02	2.04
2	DQ4	-13.00	80.50	-0.33	2.04
3	DQ12	-18.90	80.50	-0.48	2.04
4	DQ5	-24.80	80.50	-0.63	2.04
5	DQ13	-30.70	80.50	-0.78	2.04
6	DQ6	-36.50	80.50	-0.93	2.04
7	DQ14	-42.40	80.50	-1.08	2.04
8	DQ7	-48.30	80.50	-1.23	2.04
9	DQ15/A-1	-54.20	80.50	-1.38	2.04
10	V _{SS}	-63.60	78.90	-1.62	2.00
11	BYTE#	-63.60	68.90	-1.62	1.75
12	A16	-63.60	-58.80	-1.62	-1.49
13	A15	-63.30	-79.00	-1.61	-2.01
14	A14	-55.90	-79.00	-1.42	-2.01
15	A13	-50.50	-79.00	-1.28	-2.01
16	A12	-44.70	-79.00	-1.14	-2.01
17	A11	-39.30	-79.00	-1.00	-2.01
18	A10	-33.40	-79.00	-0.85	-2.01
19	A9	-28.00	-78.70	-0.71	-2.00
20	A8	-22.10	-79.00	-0.56	-2.01
21	WE#	-16.60	-79.00	-0.42	-2.01
22	RESET#	-7.10	-82.80	-0.18	-2.10
23	RY/BY#	10.20	-82.80	0.26	-2.10
24	A17	22.20	-79.00	0.56	-2.01
25	A7	28.00	-79.00	0.71	-2.01
26	A6	33.40	-79.00	0.85	-2.01
27	A5	39.30	-79.00	1.00	-2.01
28	A4	44.70	-79.00	1.14	-2.01
29	A3	50.50	-79.00	1.28	-2.01
30	A2	55.90	-79.00	1.42	-2.01
31	A1	63.30	-79.00	1.61	-2.01
32	A0	63.60	58.60	1.62	1.49
33	CE#	63.60	68.70	1.62	1.75
34	V _{SS}	63.60	78.70	1.62	2.00
35	OE#	54.20	81.40	1.38	2.07
36	DQ0	46.60	80.50	1.18	2.04
37	DQ8	40.70	80.50	1.03	2.04
38	DQ1	34.90	80.50	0.89	2.04
39	DQ9	28.90	80.50	0.73	2.04
40	DQ2	23.10	80.50	0.59	2.04
41	DQ10	17.20	80.50	0.44	2.04
42	DQ3	11.40	80.50	0.29	2.04
43	DQ11	5.40	80.50	0.14	2.04

Note: The coordinates above are relative to die center and can be used to operate wire bonding equipment.

PAD DESCRIPTIONPad locations relative to V_{CC} .

Pad	Signal	Pad Center (mils)		Pad Center (millimeters)	
		X	Y	X	Y
1	V_{CC}	0.00	0.00	0.00	0.00
2	DQ4	-12.10	0.00	-0.31	0.00
3	DQ12	-18.00	0.00	-0.46	0.00
4	DQ5	-23.90	0.00	-0.61	0.00
5	DQ13	-29.80	0.00	-0.76	0.00
6	DQ6	-35.60	0.00	-0.90	0.00
7	DQ14	-41.50	0.00	-1.05	0.00
8	DQ7	-47.40	0.00	-1.20	0.00
9	DQ15/A-1	-53.30	0.00	-1.35	0.00
10	V_{SS}	-62.70	-1.60	-1.59	-0.04
11	BYTE#	-62.70	-11.60	-1.59	-0.29
12	A16	-62.70	-21.70	-1.59	-0.55
13	A15	-62.40	-159.50	-1.58	-4.05
14	A14	-55.00	-159.50	-1.40	-4.05
15	A13	-49.60	-159.50	-1.26	-4.05
16	A12	-43.80	-159.50	-1.11	-4.05
17	A11	-38.40	-159.50	-0.98	-4.05
18	A10	-32.50	-159.50	-0.83	-4.05
19	A9	-27.10	-159.20	-0.69	-4.04
20	A8	-21.20	-159.50	-0.54	-4.05
21	WE#	-15.70	-159.50	-0.40	-4.05
22	RESET#	-6.20	-163.30	-0.16	-4.15
23	RY/BY#	11.10	-163.30	0.28	-4.15
24	A17	23.10	-159.50	0.59	-4.05
25	A7	28.90	-159.50	0.73	-4.05
26	A6	34.30	-159.50	0.87	-4.05
27	A5	40.20	-159.50	1.02	-4.05
28	A4	45.60	-159.50	1.16	-4.05
29	A3	51.40	-159.50	1.31	-4.05
30	A2	56.80	-159.50	1.44	-4.05
31	A1	64.20	-159.50	1.63	-4.05
32	A0	64.50	-21.90	1.64	-0.56
33	CE#	64.50	-11.80	1.64	-0.30
34	V_{SS}	64.50	-1.80	1.64	-0.05
35	OE#	55.10	0.90	1.40	0.02
36	DQ0	47.50	0.00	1.21	0.00
37	DQ8	41.60	0.00	1.06	0.00
38	DQ1	35.80	0.00	0.91	0.00
39	DQ9	29.80	0.00	0.76	0.00
40	DQ2	24.00	0.00	0.61	0.00
41	DQ10	18.10	0.00	0.46	0.00
42	DQ3	12.30	0.00	0.31	0.00
43	DQ11	6.30	0.00	0.16	0.00

Note: The coordinates above are relative to the die center and can be used to operate wire bonding equipment.

ORDERING INFORMATION

Standard Products

AMD standard products are available in several packages and operating ranges. The order number (Valid Combination) is formed by a combination of the following:

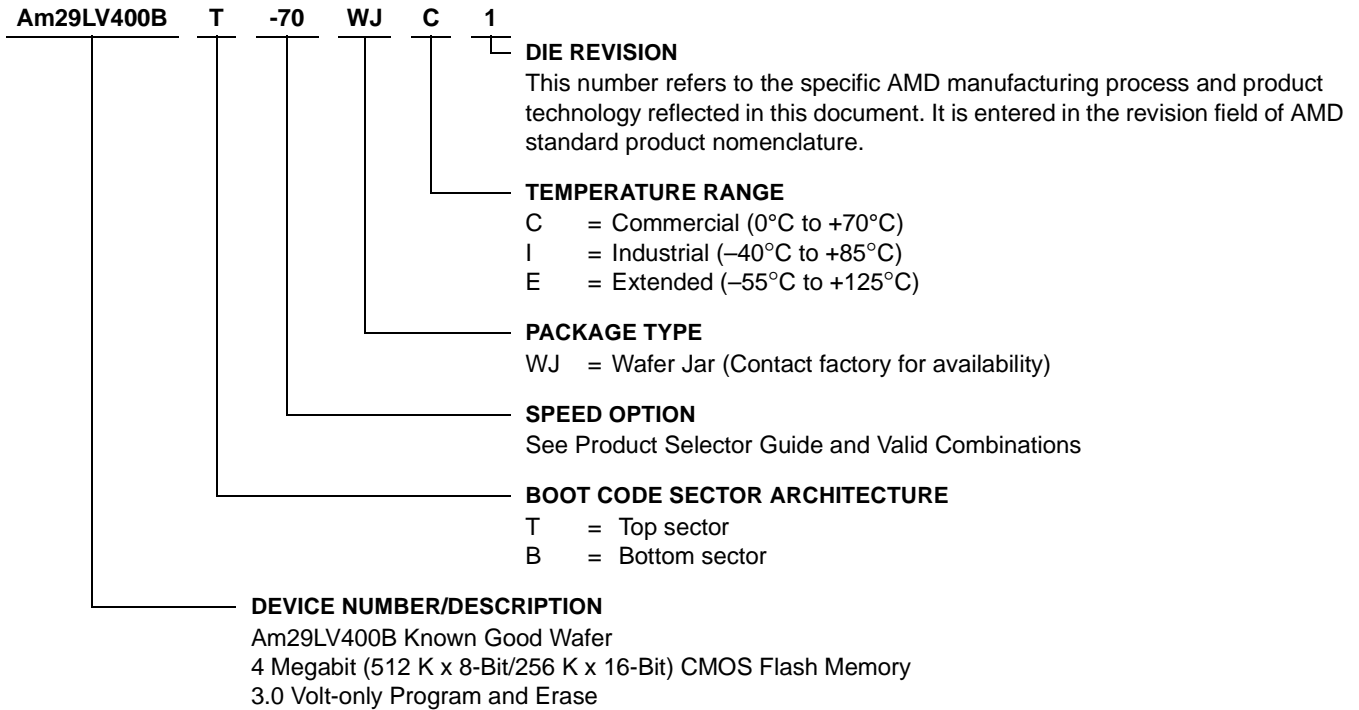

Valid Combinations		V _{CC} Range
AM29LV400BT-60R AM29LV400BB-60R	WJC 1, WJI 1	3.0–3.6 V
AM29LV400BT-70 AM29LV400BB-70		
AM29LV400BT-80 AM29LV400BB-80	WJC 1, WJI 1, WJE 1	2.7–3.6 V
AM29LV400BT-90 AM29LV400BB-90		
AM29LV400BT-120 AM29LV400BB-120		

Valid Combinations

Valid Combinations list configurations planned to be supported in volume for this device. Consult the local AMD sales office to confirm availability of specific valid combinations and to check on newly released combinations.

WAFER JAR DIAGRAM

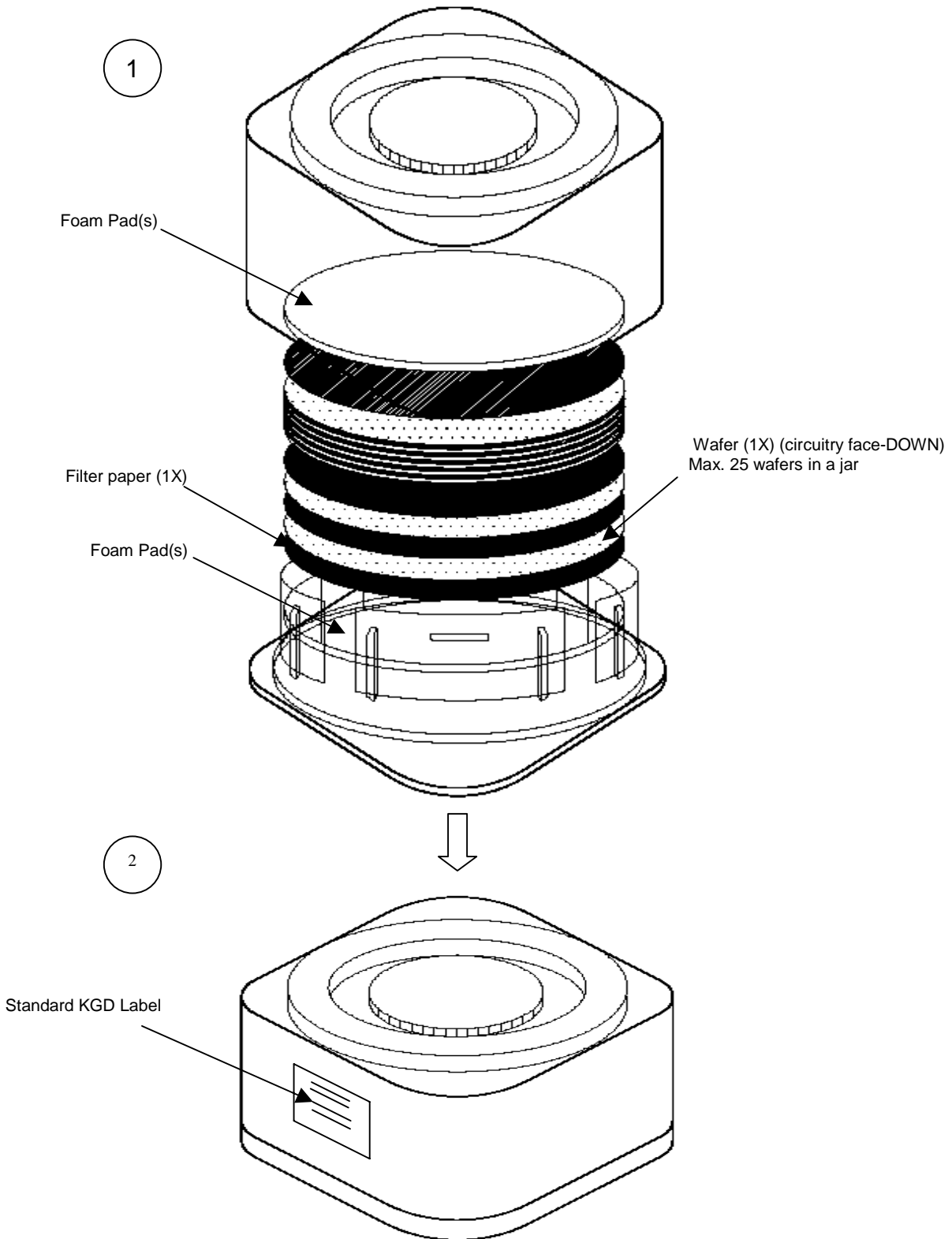

PRODUCT TEST FLOW

Figure 1 provides an overview of AMD's Known Good Wafer test flow. For more detailed information, refer to the Am29LV400B product qualification database. AMD implements quality assurance procedures throughout the product test flow. These QA procedures also allow

AMD to produce KGW products without requiring or implementing burn-in. In addition, an off-line qualification maintenance program (QMP) guarantees AMD quality standards are met on Known Good Wafer products.

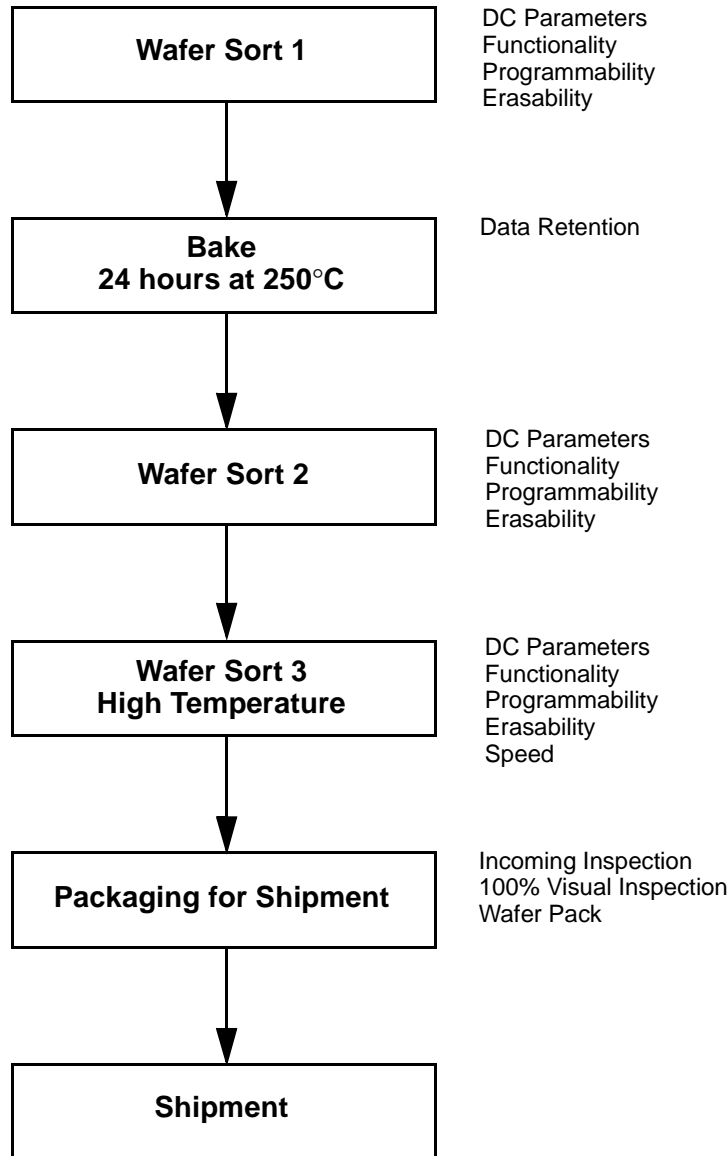

Figure 1. AMD KGW Product Test Flow

PHYSICAL SPECIFICATIONS

Wafer Size	200 mm
Active Die dimensions	x = 3462.6 μ m; y = 4470.6 μ m
	x = 136.3 mils; y = 176 mils
Scribe width	x = 87.4 μ m; y = 229.4 μ m
	x = 3.44 mils; y = 9.03 mils
Step dimensions	x = 3.56 mm; y = 4.70 mm
	x = 140 mils; y = 185 mils
Wafer Thickness	483 +/-51 μ m
Bond Pad Size	3.74 mils x 3.74 mils
	95 μ m x 95 μ m
Minimum pad pitch	137.8 μ m
	5.42 mils
Pad Area Free of Passivation	13.99 mils ²
	9,025 μ m ²
Pads Per Die	43
Bond Pad Metalization	Al/Cu
	Minimum thickness: 10500 Angstroms
Die Backside	No metal, may be grounded with Back-grind type finish (optional)
Passivation	Nitride/SOG/Nitride
	Minimum thickness: 14700 Angstroms
Ink dot height	.08 mils max
	20.3 μ m max
Ink dot diameter	.15 mils min
	381 μ m min
Edge die Inked	Yes

DC OPERATING CONDITIONS

V _{CC} (Supply Voltage)	2.7 V to 3.6 V
Operating Temperature	
Commercial	0°C to +70°C
Industrial	-40°C to +85°C
Extended	-55°C to +125°C

MANUFACTURING INFORMATION

Manufacturing	FASL
Test	Penang, Malaysia
Manufacturing ID (Top Boot)	98F03AK
(Bottom Boot)	98F03ABK
Preparation for Shipment	Penang, Malaysia
Fabrication Process	CS39S
Die Revision	1

SPECIAL HANDLING INSTRUCTIONS**Processing**

Do not expose KGW products to ultraviolet light or process them at temperatures greater than 250°C. Failure to adhere to these handling instructions will result in irreparable damage to the devices. For best yield, AMD recommends assembly in a Class 10K clean room with 30% to 60% relative humidity.

Storage

Store at a maximum temperature of 30°C in a nitrogen-purged cabinet or vacuum-sealed bag. Observe all standard ESD handling procedures.

TERMS AND CONDITIONS OF SALE FOR AMD NON-VOLATILE MEMORY DIE

All transactions relating to unpackaged die or unpackaged wafer(s) under this agreement shall be subject to AMD's standard terms and conditions of sale, or any revisions thereof, which revisions AMD reserves the right to make at any time and from time to time. In the event of conflict between the provisions of AMD's standard terms and conditions of sale and this agreement, the terms of this agreement shall be controlling.

AMD warrants its manufactured unpackaged die whether shipped to customer in individual dice or wafer form ("Known Good Die," "KGD", "Die," "Known Good Wafer", "KGW", or Wafer(s)) will meet AMD's published specifications and against defective materials or workmanship for a period of one (1) year from date of shipment.

This limited warranty does not extend beyond the first purchaser of said Die or Wafer(s).

Buyer assumes full responsibility to ensure compliance with the appropriate handling, assembly and processing of KGD or KGW (including but not limited to proper Die preparation, Die attach, backgrinding, singulation, wire bonding and related assembly and test activities), and compliance with all guidelines set forth in AMD's specifications for KGD or KGW, and AMD assumes no responsibility for environmental effects on KGD or KGW or for any activity of Buyer or a third party that damages the Die or Wafer(s) due to improper use, abuse, negligence, improper installation, improper backgrinding, improper singulation, accident, loss, damage in transit, or unauthorized repair or alteration by a person or entity other than AMD ("Limited Warranty Exclusions")

The liability of AMD under this limited warranty is limited, at AMD's option, solely to repair the Die or Wafer(s), to send replacement Die or Wafer(s), or to make an appropriate credit adjustment or refund in an amount not to exceed the original purchase price actually paid for the Die or Wafer(s) returned to AMD, provided that: (a) AMD is promptly notified by Buyer in writing during the applicable warranty period of any defect or nonconformity in the Die or Wafer(s); (b) Buyer obtains authorization from AMD to return the defective Die or Wafer(s); (c) the defective Die or Wafer(s) is returned to AMD by Buyer in accordance with AMD's shipping instructions set forth below; and (d) Buyer shows to AMD's satisfaction that such alleged defect or nonconformity actually exists and was not caused by any of the above-referenced Warranty Exclusions. Buyer shall ship such defective Die or Wafer(s) to AMD via AMD's carrier, collect. Risk of loss will transfer to AMD when the defective Die or Wafer(s) is provided to AMD's carrier. If Buyer fails to adhere to these warranty returns guidelines, Buyer shall assume all risk of loss and shall pay for all freight to AMD's

specified location. The aforementioned provisions do not extend the original limited warranty period of any Die or Wafer(s) that has either been replaced by AMD.

THIS LIMITED WARRANTY IS EXPRESSED IN LIEU OF ALL OTHER WARRANTIES, EXPRESSED OR IMPLIED, INCLUDING THE IMPLIED WARRANTY OF FITNESS FOR A PARTICULAR PURPOSE, THE IMPLIED WARRANTY OF MERCHANTABILITY OR NONINFRINGEMENT AND OF ALL OTHER OBLIGATIONS OR LIABILITIES ON AMD'S PART, AND IT NEITHER ASSUMES NOR AUTHORIZES ANY OTHER PERSON TO ASSUME FOR AMD ANY OTHER LIABILITIES. THE FOREGOING CONSTITUTES THE BUYER'S SOLE AND EXCLUSIVE REMEDY FOR THE FURNISHING OF DEFECTIVE OR NON CONFORMING KNOWN GOOD DIE OR KNOWN GOOD WAFER(S) AND AMD SHALL NOT IN ANY EVENT BE LIABLE FOR INCREASED MANUFACTURING COSTS, DOWNTIME COSTS, DAMAGES RELATING TO BUYER'S PROCUREMENT OF SUBSTITUTE DIE OR WAFER(S) (i.e., "COST OF COVER"), LOSS OF PROFITS, REVENUES OR GOODWILL, LOSS OF USE OF OR DAMAGE TO ANY ASSOCIATED EQUIPMENT, OR ANY OTHER INDIRECT, INCIDENTAL, SPECIAL OR CONSEQUENTIAL DAMAGES BY REASON OF THE FACT THAT SUCH KNOWN GOOD DIE OR KNOWN GOOD WAFER(S) SHALL HAVE BEEN DETERMINED TO BE DEFECTIVE OR NON CONFORMING.

Buyer agrees that it will make no warranty representations to its customers which exceed those given by AMD to Buyer unless and until Buyer shall agree to indemnify AMD in writing for any claims which exceed AMD's limited warranty. Known Good Die or Known Good Wafer(s) are not designed or authorized for use as components in life support appliances, devices or systems where malfunction of the Die or Wafer(s) can reasonably be expected to result in a personal injury. Buyer's use of Known Good Die or Known Good Wafer(s) for use in life support applications is at Buyer's own risk and Buyer agrees to fully indemnify AMD for any damages resulting in such use or sale.

Known Good Die or Known Good Wafer are not designed or authorized for use as components in life support appliances, devices or systems where malfunction of the die or wafer can reasonably be expected to result in a personal injury. Buyer's use of Known Good Die or Known Good Wafer for use in life support applications is at Buyer's own risk and Buyer agrees to fully indemnify AMD for any damages resulting in such use or sale.

REVISION SUMMARY**Revision A (June 19, 2002)**

Initial release.

Revision B (April 18, 2003)

Updated General Description and Distinctive Characteristics.

Die Pad Locations

Added X and Y axis marker.

Product Test Flow

Updated text.

Physical Specifications

Added ACtive Die Dimensions, Scribe Width, Step Dimensions, Minimum Pad Pitch, Ink dot height, Ink dot diameter, and Edge Die Inked specifications.

Terms and Conditions of sale for AMD Non-volatile memory die

Updated text following first paragraph.

Trademarks

Copyright © 2003 Advanced Micro Devices, Inc. All rights reserved.

AMD, the AMD logo, and combinations thereof are registered trademarks of Advanced Micro Devices, Inc.

Product names used in this publication are for identification purposes only and may be trademarks of their respective companies.